

OPERATION MANUAL

MARINE ENGINES

6CX530

**California
Proposition 65 Warning**

Diesel engine exhaust and some of its constituents are known to the state of California to cause cancer, birth defects, and other reproductive harm.

**California
Proposition 65 Warning**

Battery posts, terminals, and related accessories contain lead and lead compounds, chemicals known to the state of California to cause cancer and reproductive harm.
Wash hands after handling.

Disclaimers:

All information, illustrations and specifications in this manual are based on the latest information available at the time of publishing. The illustrations used in this manual are intended as representative reference views only. Moreover, because of our continuous product improvement policy, we may modify information, illustrations and/or specifications to explain and/or exemplify a product, service or maintenance improvement. We reserve the right to make any change at any time without notice. Yanmar and **YANMAR** are registered trademarks of Yanmar Co., Ltd. in Japan, the United States and/or other countries.

All Rights Reserved:

No part of this publication may be reproduced or used in any form by any means - graphic, electronic, or mechanical, including photocopying, recording, taping, or information storage and retrieval systems - without the written permission of Yanmar Marine International.

©2009 Yanmar Marine International

Date of issue: Sep. 2009

TABLE OF CONTENTS

	Page
Introduction	1
Record of Ownership	2
Safety	3
Safety Precautions	4
General Information	4
Before You Operate	4
During Operation and Maintenance.....	5
Location of Safety Decals	8
Product Overview	11
Yanmar 6CX Features and Applications	11
New Engine Break-In.....	12
Component Identification	13
Service Side	13
Non-Service Side.....	15
Location of Nameplates	17
Function of Major Components	18
Electronic Control System (ECS)	19
Display	20
Before You Operate	27
Diesel Fuel	27
Diesel Fuel Specifications	27
Filling the Fuel Tank	32
Bleeding the Fuel System.....	34
Engine Oil.....	36
Engine Oil Specifications	36
Engine Oil Viscosity	36
Engine Oil System	37
Checking the Engine Oil	39

TABLE OF CONTENTS

Adding Engine Oil	40
Marine Gear Oil	40
Marine Gear Oil Specifications.....	40
Checking the Marine Gear Oil.....	40
Adding Marine Gear Oil.....	41
Engine Coolant	41
Engine Coolant Specifications	41
Coolant (Closed Cooling System)	41
Checking and Adding Coolant.....	42
Checking the Engine Oil and Engine Coolant	43
Engine Operation	45
Starting the Engine	48
Before Starting the Engine	48
Starting the Engine.....	48
Shifting	50
Cautions During Operation	51
Shutting Down the Engine	52
Normal Shutdown.....	52
Emergency Shutdown	52
Checking the Engine After Operation	53
Periodic Maintenance	55
Safety Precautions	55
Precautions.....	57
The Importance of Periodic Maintenance	57
Performing Periodic Maintenance	57
The Importance of Daily Checks	57
Keep a Log of Engine Hours and Daily Checks .	58
Yanmar Replacement Parts	58
Tools Required.....	58
Ask Your Authorized Yanmar Marine Dealer or Distributor for Help	58
Tightening Fasteners	59
EPA Maintenance Requirements	60
EPA Requirements for USA and Other Applicable Countries	60
EPA Requirements.....	60
Conditions to Ensure Compliance with EPA Emission Standards	60
Inspection and Maintenance	60
Periodic Maintenance Schedule	61

Inspection and Maintenance of EPA Emission-Related Parts	64
Periodic Maintenance Procedures	65
Daily Checks.....	65
After Initial 50 Hours of Operation	66
Every 50 Hours of Operation	70
Every 250 Hours of Operation	72
Every 500 Hours of Operation	81
Every 1000 Hours of Operation	82
Long-Term Storage	83
Preparing the Engine for Long-Term Storage	83
Draining the Seawater Cooling System	84
Troubleshooting	87
Troubleshooting After Starting	87
Troubleshooting Information	88
Troubleshooting Chart.....	89
Failsafe Diagnosis Functional Specification Chart ...	95
Specifications	101
Principal Engine Specifications	101
6CX530 Engine Specifications	101
6CX530 Marine Gear Specifications	102
System Diagrams	103
Piping Diagrams.....	103
6CX530 with KMH70A Marine Gear.....	104
Wiring Diagrams.....	106
EPA Warranty USA Only	107
Yanmar Co., Ltd. Limited Emission Control	
System Warranty - USA Only.....	107
Your Warranty Rights and Obligations:	107
Warranty Period:.....	108
Warranty Coverage:	108
Exclusions:	108
Owner's Responsibility:	109
Customer Assistance:.....	109
Maintenance Log	110

This Page Intentionally Left Blank

INTRODUCTION

Welcome to the world of Yanmar Marine! Yanmar Marine offers engines, drive systems and accessories for all types of boats, from runabouts to sailboats, and from cruisers to mega yachts. In marine leisure boating, the worldwide reputation of Yanmar Marine is second to none. We design our engines to respect nature. This means quieter engines, with minimal vibrations, cleaner than ever. All of our engines meet applicable regulations, including emissions, at the time of manufacture.

To help you enjoy your Yanmar 6CX series engine for many years to come, please follow these recommendations:

- Read and understand this *Operation Manual* before you operate the machine to ensure that you follow safe operating practices and maintenance procedures.
- Keep this *Operation Manual* in a convenient place for easy access.
- If this *Operation Manual* is lost or damaged, order a new one from your authorized Yanmar Marine dealer or distributor.
- Make sure this manual is transferred to subsequent owners. This manual should be considered a permanent part of the engine and remain with it.
- Constant efforts are made to improve the quality and performance of Yanmar products, so some details included in this *Operation Manual* may differ slightly from your engine. If you have any questions about these differences, please contact your authorized Yanmar Marine dealer or distributor.
- The specifications and components (instrument panel, fuel tank, etc.) described in this manual may differ from ones installed on your vessel. Please refer to the manual provided by the manufacturer of these components.
- Refer to the Yanmar Limited Warranty Handbook for a complete warranty description.

INTRODUCTION

RECORD OF OWNERSHIP

Take a few moments to record the information you need when you contact Yanmar for service, parts or literature.

Engine Model: _____

Engine Serial No.: _____

Date Purchased: _____

Dealer: _____

Dealer Phone: _____

SAFETY

Yanmar considers safety of great importance and recommends that anyone that comes into close contact with its products, such as those who install, operate, maintain or service Yanmar products, exercise care, common sense and comply with the safety information in this manual and on the machine's safety decals. Keep the labels from becoming dirty or torn and replace them if they are lost or damaged. Also, if you need to replace a part that has a label attached to it, make sure you order the new part and label at the same time.



This safety alert symbol appears with most safety statements. It means attention, become alert, your safety is involved! Please read and abide by the message that follows the safety alert symbol.

DANGER

Indicates a hazardous situation which, if not avoided, *will* result in death or serious injury.

WARNING

Indicates a hazardous situation which, if not avoided, *could* result in death or serious injury.

CAUTION

Indicates a hazardous situation which, if not avoided, *could* result in minor or moderate injury.

NOTICE

Indicates a situation which can cause damage to the machine, personal property and / or the environment or cause the equipment to operate improperly.

SAFETY PRECAUTIONS

General Information

There is no substitute for common sense and careful practices. Improper practices or carelessness can cause burns, cuts, mutilation, asphyxiation, other bodily injury or death. This information contains general safety precautions and guidelines that must be followed to reduce risk to personal safety. Special safety precautions are listed in specific procedures. Read and understand all of the safety precautions before operation or performing repairs or maintenance.

Before You Operate

⚠ DANGER

The safety messages that follow have DANGER level hazards.



NEVER permit anyone to install or operate the engine without proper training.

- Read and understand this *Operation Manual* before you operate or service the engine to ensure that you follow safe operating practices and maintenance procedures.
- Safety signs and labels are additional reminders for safe operating and maintenance techniques.
- See your authorized Yanmar Marine dealer or distributor for additional training.

During Operation and Maintenance

DANGER

The safety message that follows has DANGER level hazards.



Crush Hazard

NEVER stand under hoisted engine. If the hoist mechanism fails, the engine will fall on you.

WARNING

The safety messages that follow have WARNING level hazards.

Explosion Hazard

 While the engine is running or the battery is charging, hydrogen gas is being produced and can be easily ignited. Keep the area around the battery well-ventilated and keep sparks, open flames and any other form of ignition out of the area.

Fire and Explosion Hazard

Diesel fuel is flammable and explosive under certain conditions.

NEVER use a shop rag to catch the fuel.

Wipe up all spills immediately.

NEVER refuel with the engine running.

NEVER use diesel fuel as a cleaning agent.

Store any containers containing fuel or other flammable products in a well-ventilated area, away from any combustibles or sources of ignition.

Fire Hazard



Undersized wiring systems can cause an electrical fire.

Store any equipment in a designated area away from moving parts.

NEVER use the engine compartment for storage.

⚠ WARNING

Sever Hazard



Rotating parts can cause severe injury or death. NEVER wear jewelry, unbuttoned cuffs, ties or loose fitting clothing and ALWAYS

tie long hair back when working near moving / rotating parts such as the flywheel or PTO shaft. Keep hands, feet and tools away from all moving parts. NEVER operate the engine without the guards in place.

Alcohol and Drug Hazard



NEVER operate the engine while under the influence of alcohol or drugs or feeling ill.

Exposure Hazard



ALWAYS wear personal protective equipment including appropriate clothing, gloves, work shoes, eye and hearing protection as required by the task at hand.

Entanglement Hazard



NEVER leave the key in the key switch when you are servicing the engine. Someone may accidentally start the engine and not

realize you are servicing it.

NEVER operate the engine while wearing a headset to listen to music or radio because it will be difficult to hear the warning signals.

Piercing Hazard



Avoid skin contact with high-pressure diesel fuel spray caused by a fuel system leak such as a broken fuel injection line.

High-pressure fuel can penetrate your skin and result in serious injury. If you are exposed to high-pressure fuel spray, obtain prompt medical treatment.

NEVER check for a fuel leak with your hands. ALWAYS use a piece of wood or cardboard. Have your authorized Yanmar Marine dealer or distributor repair the damage.

Burn Hazard



Some of the engine surfaces become very hot during operation and shortly after shut-down.

Keep hands and other body parts away from hot engine surfaces.

Sudden Movement Hazard

ALWAYS stop the engine before beginning service.

Exhaust Hazard



NEVER block windows, vents or other means of ventilation if the engine is operating in an enclosed area. All internal combustion

engines create carbon monoxide gas during operation and special precautions are required to avoid carbon monoxide poisoning.

CAUTION

The safety messages that follow have CAUTION level hazards.

Poor Lighting Hazard

Ensure that the work area is adequately illuminated. ALWAYS install wire cages on portable safety lamps.

Tool Hazard

ALWAYS use tools appropriate for the task at hand and use the correct size tool for loosening or tightening machine parts.

Flying Object Hazard

ALWAYS wear eye protection when servicing the engine or when using compressed air or high-pressure water. Dust, flying debris, compressed air, pressurized water or steam may injure your eyes.

Coolant Hazard

Wear eye protection and rubber gloves when you handle Long Life engine coolant. If contact with the eyes or skin should occur, flush eyes and wash immediately with clean water.

NOTICE

The safety messages that follow have NOTICE level hazards.

It is important to perform daily checks as listed in the *Operation Manual*.

Periodic maintenance prevents unexpected downtime, reduces the number of accidents due to poor engine performance and helps extend the life of the engine.

See your authorized Yanmar Marine dealer or distributor if you need to operate the engine at high altitudes. At high altitudes the engine will lose power, run rough and produce exhaust gases that exceed the design specifications.



ALWAYS be environmentally responsible.

Follow the guidelines of the EPA or other governmental agencies for the proper disposal of hazardous materials such as engine oil, diesel fuel and engine coolant. Consult the local authorities or reclamation facility.

NEVER dispose of hazardous materials by dumping them into a sewer, on the ground or into ground water or waterways.

If a Yanmar Marine Engine is installed at an angle that exceeds the specifications stated in the Yanmar Marine Installation manuals, engine oil may enter the combustion chamber causing excessive engine speed, white exhaust smoke and serious engine damage. This applies to engines that run continuously or those that run for short periods of time.

LOCATION OF SAFETY DECALS

Figure 1 and Figure 2 show the location of safety decals on Yanmar 6CX530 series marine engines.

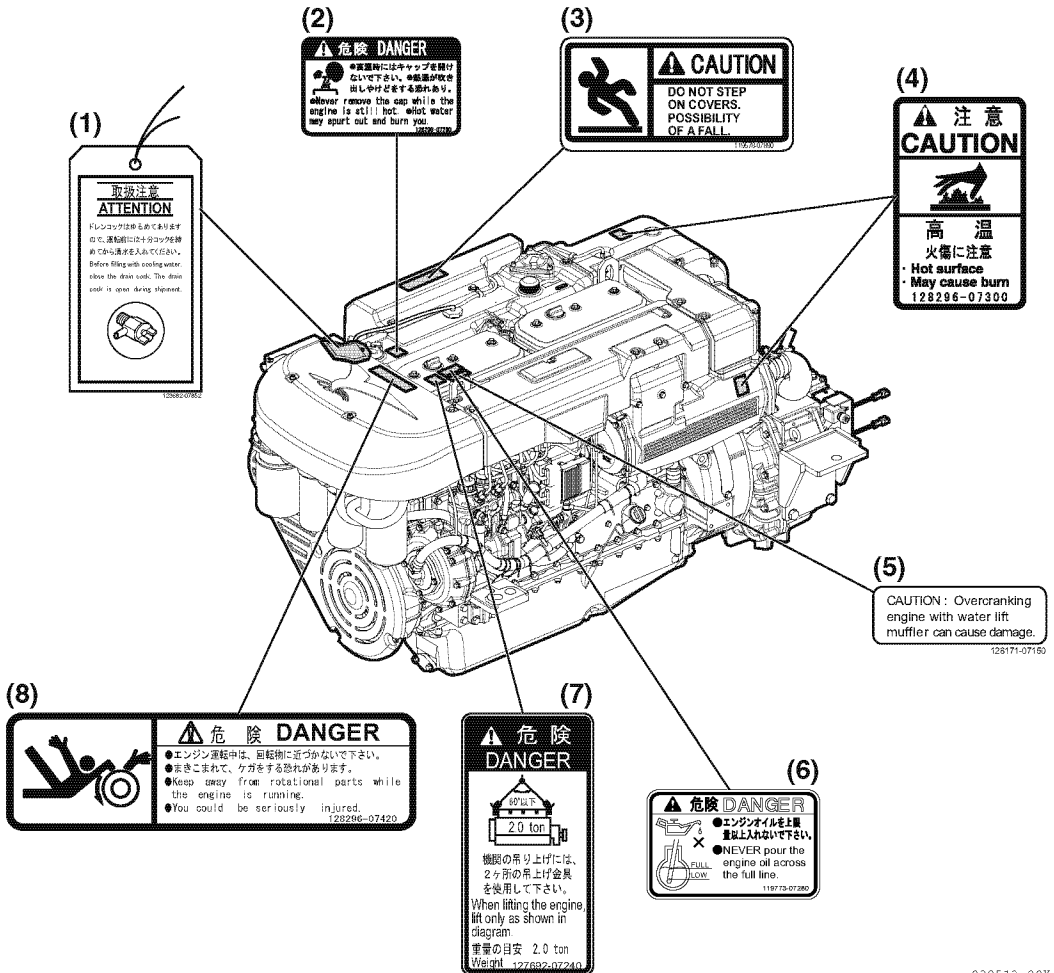

Figure 1

- 1 – Part Number: 123682-07852
- 2 – Part Number: 128296-07260
- 3 – Part Number: 119578-07890
- 4 – Part Number: 128296-07300

- 5 – Part Number: 128171-07150
- 6 – Part Number: 119773-07280
- 7 – Part Number: 127692-07240
- 8 – Part Number: 128296-07420

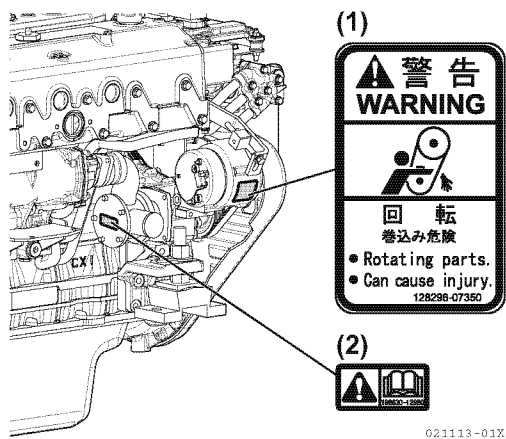

Figure 2

1 – Part Number: 128296-07350

2 – Part Number: 196630-12980

This Page Intentionally Left Blank

PRODUCT OVERVIEW

YANMAR 6CX FEATURES AND APPLICATIONS

The 6CX series are four-stroke direct injection diesel engines equipped with liquid coolant systems.

The 6CX530 is 6-cylinder and turbocharged with an intercooler and equipped a common rail fuel injection system and a marine gear.

This engine is designed for pleasure craft use.

It is recommended that new vessels be propped so the engines can operate at 95% load at 2900 rpm.

Failure to do so can lead to reduced vessel performance, lead to increased smoke levels and cause permanent damage to your engine.

The engine must be installed correctly with coolant lines, exhaust gas lines and electrical wiring. Any auxiliary equipment attached to the engine should be easy to use and accessible for service. To handle the drive equipment, propulsion systems (including the propeller) and other onboard equipment, always observe the instructions and cautions given in the operation manuals supplied by the shipyard and equipment manufacturers.

The 6CX530 series engines are designed to be operated at maximum throttle (2875 to 2925 rpm) for less than 5% of total engine time (30 minutes out of every 10 hours) and cruising speed (2800 rpm or less) for less than 90% of total engine time (9 hours out of every 10 hours).

The laws of some countries may require hull and engine inspections, depending on the use, size and cruising area of the boat. The installation, fitting and surveying of this engine all require specialized knowledge and engineering skills. See Yanmar's local subsidiary in your region or your authorized Yanmar Marine dealer or distributor.

PRODUCT OVERVIEW

New Engine Break-In

As with all reciprocating engines, the way your engine is operated during its first 50 hours of operation plays a very significant role in determining how long it will last and how well the engine will perform over its lifetime.

A new Yanmar diesel engine must be operated at suitable speeds and power settings during the break-in period to make the sliding parts, such as piston rings, break-in properly and to stabilize engine combustion.

During the break-in period, the engine coolant temperature gauge should be monitored, temperature should be lower than 80°C (176°F).

During the first 10 hours of operation, the engine should be run at maximum rpm minus 400 to 500 rpm (approximately 60 to 70% of load) most of the time. This will ensure the sliding parts break in properly. During this period, avoid operating at maximum engine speed and load to avoid damaging or scoring sliding parts.

NOTICE: Do not operate at WOT (wide open throttle) for more than a minute at a time during the first 10 hours of operation.

Do not operate the engine at low idle or at low speed and light load for more than 30 minutes at a time. Since unburned fuel and engine oil will adhere to the piston rings when operating at low speeds for long periods, this will interfere with proper movement of the rings and the lube oil consumption may increase. Low idle speed does not allow break-in of sliding parts.

If operating engine at low speed and light load, you must race the engine to clean the carbon from the cylinders and fuel injection valve.

Perform this procedure in open waters:

- With the clutch in NEUTRAL, accelerate from the low speed position to the high speed position briefly.
- Repeat this process five times.

Once past the initial 10 hours until 50 hours, the engine should be used over its full operating range, with special emphasis on running at relatively high power settings. This is not the time for an extended cruise at idle or low speed. The boat should be run at maximum speed minus 400 rpm most of the time (approximately 70% load), with a 10 minute run at maximum minus 200 rpm (approximately 80% load) every 30 minutes and a 4-5 minute period of operation at WOT (wide open throttle) once each 30 minutes. During this period, be sure not to operate your engine at low speed and light load for more than 30 minutes. If operating engine at low speed and light load by necessity, just after the low idle operation, be sure to race the engine.

To complete engine break-in, perform *After Initial 50 Hours* maintenance procedures on page 66.

COMPONENT IDENTIFICATION

Service Side

Figure 1 and **Figure 2** illustrate a typical version of a 6CX530 engine. Your engine may have different equipment from that illustrated.

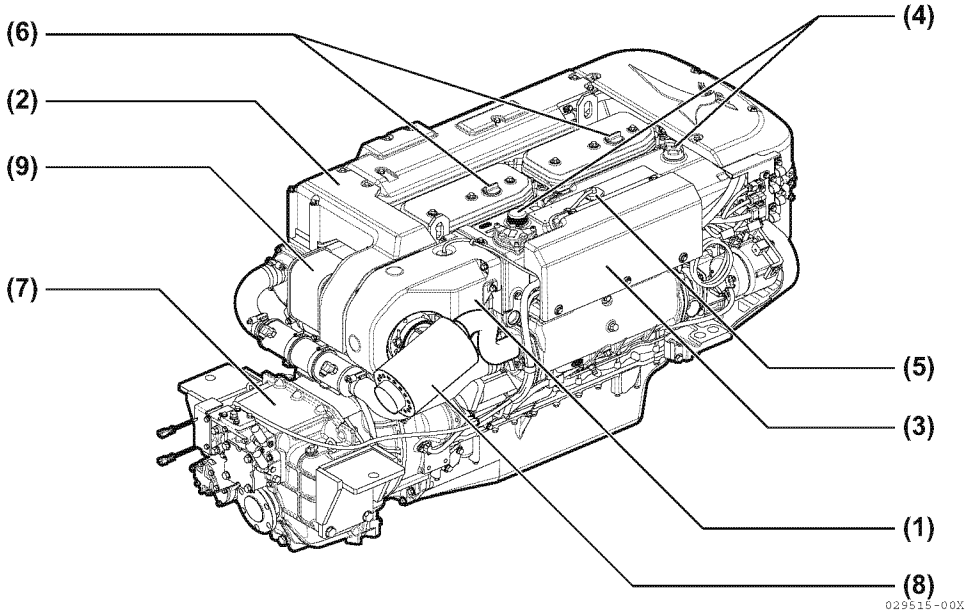

Figure 1

- | | |
|---|---|
| <ul style="list-style-type: none"> 1 – Turbocharger Cover (Water Cooled) 2 – Compressor and Air Duct Cover 3 – Plastic Cover for Relay and Fuse Box (No Step) 4 – Coolant Filler Caps (Alternative 2 Locations) 5 – Coolant Level Sensor | <ul style="list-style-type: none"> 6 – Lube Oil Filler Caps (2 Locations) 7 – Marine Gear KMH70A KANZAKI (Electronic Shift Only) 8 – Mixing Elbow (Not Supplied by Yanmar) 9 – Air Filter |
|---|---|

Service Side (continued)

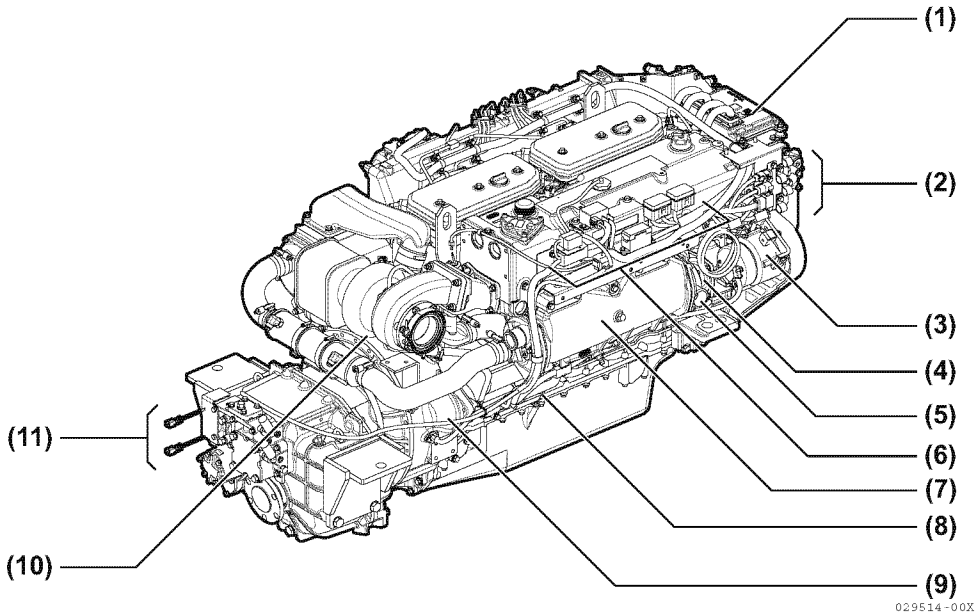
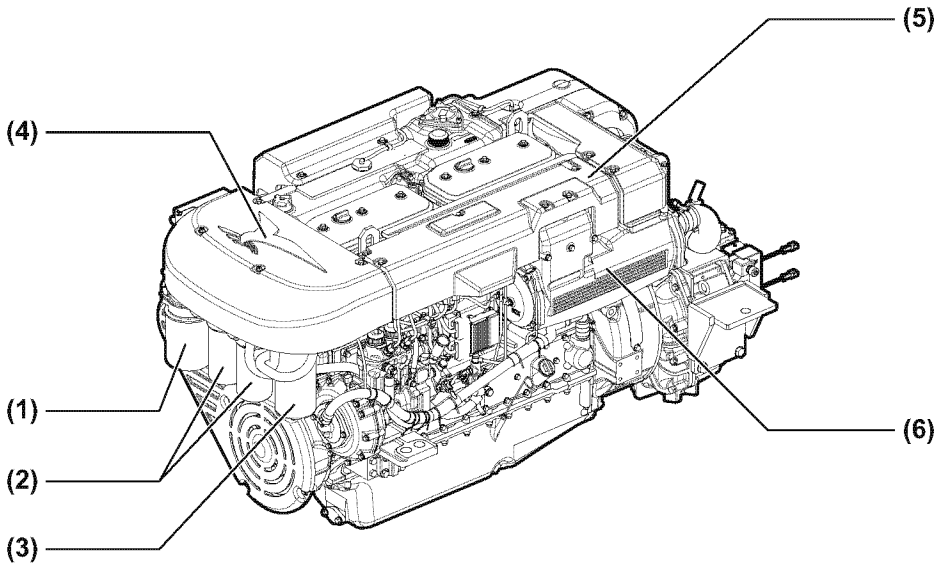

Figure 2

- | | |
|--|--|
| 1 – Engine Control Unit | 7 – Heat Exchanger |
| 2 – Connectors for Control Panel
and YANMAR Diagnostic Tool
(YDT) | 8 – Dipstick |
| 3 – Alternator | 9 – Starter |
| 4 – Seawater Pump | 10 – Turbocharger |
| 5 – Seawater Inlet | 11 – Connectors for Marine Gear
Control |
| 6 – All Relays and Fuses | |

Non-Service Side



029516-00X

Figure 3

- | | |
|---|---|
| <ul style="list-style-type: none"> 1 – Lube Oil Filter (Bypass) 2 – Lube Oil Filters (Full Flow) 3 – Fuel Filter 4 – Cover for Engine Control Unit
(Can Be Stepped) | <ul style="list-style-type: none"> 5 – Intake Manifold Cover (Can be
Stepped) 6 – Charge Air Cooler |
|---|---|

Non-Service Side (continued)

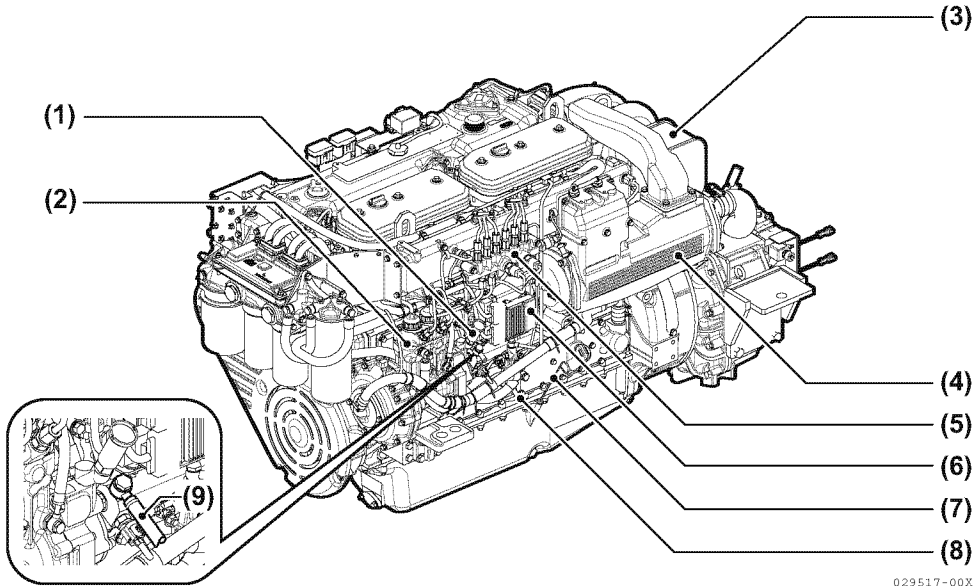

029517-00X

Figure 4

- 1 – Fuel Priming Pump and Fuel Feed Pump**
- 2 – High Pressure Fuel Pump**
- 3 – Air Duct**
- 4 – Charge Air Cooler**
- 5 – Common Rail (CR)**

- 6 – Electronic Driver Unit for Fuel Injector and Fuel Pressure Control Valve**
- 7 – Dipstick**
- 8 – Fuel Return**
- 9 – Fuel Inlet**

LOCATION OF NAMEPLATES

The nameplates of Yanmar 6CX series engines are shown in **Figure 5**. Check the engine's model, output, rpm and serial number on the nameplate. Please replace if damaged or lost.

The engine nameplate is attached to the top surface of the engine exhaust manifold (**Figure 6**).

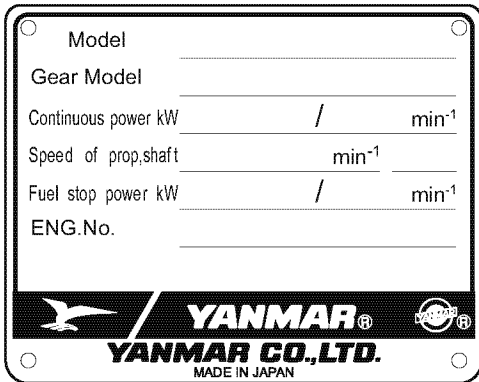

119175-07202

Figure 5

The marine gear nameplate (**Figure 7**) is attached to the marine gear. Check the marine gear's model, gear ratio, oil used, oil quantity and serial number.

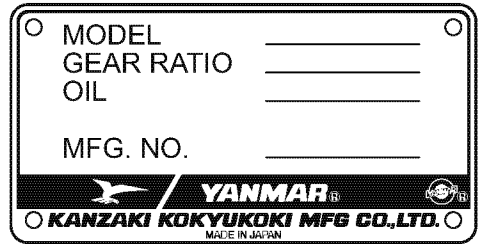

(177524-02902)

Figure 7

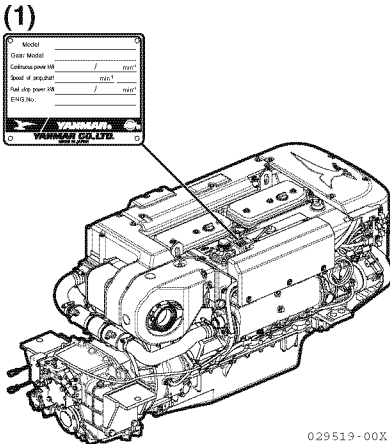

029519-00X

Figure 6

1 – Part Number – 119175-07202

PRODUCT OVERVIEW

FUNCTION OF MAJOR COMPONENTS

Name of Component	Function
Fuel Filter	Removes dirt and water from the fuel. Drain the filter periodically. The filter element should be replaced periodically. The fuel / water separator (if equipped) should be drained periodically. <i>See Draining the Fuel / Water Separator on page 70.</i>
Fuel Feed Pump	Pumps fuel from the tank to the fuel injection system.
Fuel Priming Pump	This is a manual fuel pump. Pushing the knob on the top of the fuel filter feeds the fuel. The pump is also used to bleed air from the fuel system.
Engine Oil Filler Port	Filler port for engine oil.
Engine Oil Filter	Filters fine metal fragments and carbon from the engine oil. Filtered engine oil is distributed to the engine's moving parts. The filter is a cartridge type and the element should be replaced periodically. <i>See Changing the Engine Oil and Replacing the Engine Oil Filter Element on page 74.</i>
Marine Gear Filler Port	Filler port for marine gear lube oil. Located on top of the marine gear case.
Cooling System	There are two cooling systems: closed cooling with coolant (freshwater) and seawater. The engine is cooled by the closed cooling circuit. The closed circuit is cooled by seawater using a heat exchanger. The seawater also cools the engine / marine gear oil and intake air (depending on model) through the cooler(s) in an open circuit.
Closed Cooling Circulation Pump	The centrifugal water pump circulates coolant inside the engine. The circulating pump is driven by a belt.
Seawater Pump	Pumps seawater from outside vessel to the engine. The seawater pump is gear-driven and has a replaceable rubber impeller. NEVER operate it without seawater, as this will damage the impeller.
Coolant Filler Cap	When the coolant temperature rises, the pressure inside the coolant tank increases and opens the pressure valve in the filler cap. When the pressure valve in the filler cap is opened, hot water and steam pass through a rubber hose to the coolant recovery tank. When the engine cools and the pressure inside the coolant recovery tank drops, the vacuum valve in the filler cap opens and the coolant in the coolant recovery tank returns to the water tank through the pipe and filler cap. This minimizes coolant consumption.
Coolant Recovery Tank	The pressure valve in the filler cap releases vapor and hot water overflow to the coolant recovery tank. When the engine stops and the coolant cools, the pressure in the coolant tank drops. The filler cap vacuum valve then opens to send water back from the coolant recovery tank. This minimizes coolant consumptions. The closed cooling system coolant level can easily be checked and refilled in this tank.
Oil Cooler - Engine	A heat exchanger that cools high temperature engine oil using coolant.
Oil Cooler - Marine Gear (Optional)	This heat exchanger that cools the marine gear (KMH70A) oil using seawater.
Turbocharger (if equipped)	The turbocharger pressurizes the air coming into the engine. It is driven by a turbine that is energized by exhaust gases.
Charge Air Cooler	This heat exchanger cools the pressurized charging air from the turbocharger with seawater to increase the charging air quantity.
Intake Silencer (Air Cleaner)	The intake silencer guards against dirt in the air and reduces the noise of air intake.
Nameplates	Nameplates are provided on the engine and the marine gear and have the model, serial number and other data.
Starter	Starter motor for the engine. Powered by the battery.
Alternator	Driven by belt and generates electricity and charges the battery.
Engine Oil Dipstick	Gauge stick for checking the engine oil level.

ELECTRONIC CONTROL SYSTEM (ECS)

Typical twin installation of a 6CX530 engine control system is shown in **Figure 8**.

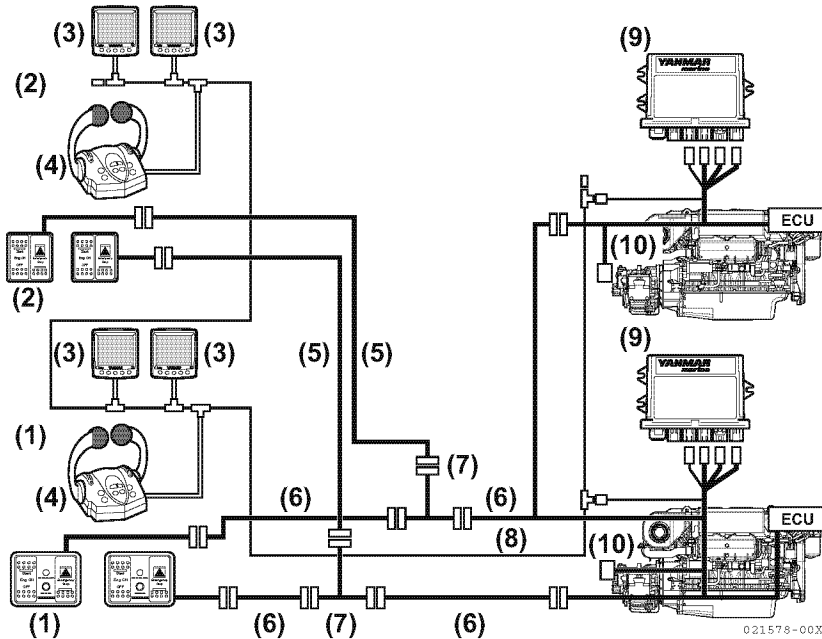

Figure 8

- 1 – 1st Station
- 2 – 2nd Station
- 3 – Digital Display
- 4 – Shift and Throttle Control Head
- 5 – 2nd Station Extension
- 6 – Extension Harness
- 7 – Y-Harness
- 8 – NMEA 2000® CANBus-Cable
- 9 – Module for Trolling Version
- 10 – Gear Control

PRODUCT OVERVIEW

Display

The multi-function information display has the following functions.

Display Function

Runtime Engine Data Tri-Screen

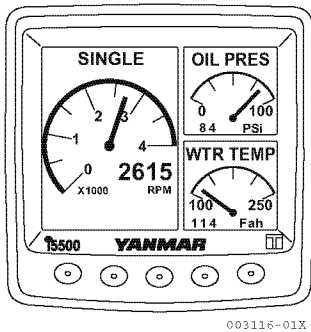

Figure 9

This screen displays real time engine data and alarm indications.

Alarm Indicators

YANMAR marine DUAL PORT Alarms	
HOT ENGINE	CHECK ENGINE
OVER REV	EMERGENCY
OIL PRESSURE	LOW VOLTAGE
TURBO BOOST	ALTERNATOR
GEAR OIL	SEA WATER FLOW
ENG COM ERROR	LOW COOLANT
MAINTENANCE	WATER IN FUEL
NETWORK	THROTTLE PROBLEM

003120-02X

Figure 10

The alarm window appears with an audible alarm when abnormal engine activity occurs.

Note: When starting the engine, make it a rule to check that when the rocker switch is pushed to the ON position, the welcome screen appears on the display and goes out about three seconds later. If the system does not function normally, contact your authorized Yanmar Marine dealer and ask for diagnostics.

Alarm Log Screen

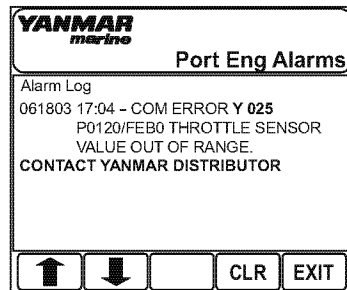

003121-02X

Figure 11

Alarm Indicator Functions

The alarm indicators and buzzer are activated when sensors detect an abnormality during engine operation. The alarm indicators are off during normal operation, but are activated as follows when an abnormality arises:

- The coolant temperature alarm indicator activates when the fresh water gets too hot.
- The engine oil pressure alarm indicator activates when the engine oil pressure drops.
- The electric charge alarm indicator activates when there is a charging failure.

Rocker Switch Panel

The rocker switch panel has the following functions.

1st Station Panel

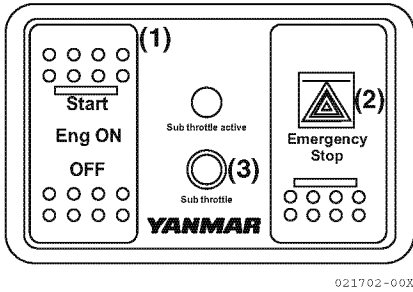

Figure 12

- To start and stop the engine:
 - To start the engine, push upper half of ignition switch (Start).
 - To stop the engine, push bottom half of ignition switch (OFF).

- Emergency stop. Use this switch only in an emergency.

NOTICE: Under normal circumstances, use the ignition switch (Figure 12, (1)) to stop the engine. The engine shuts down suddenly when the upper half of the Emergency Stop switch (Figure 12, (2)) is pushed. Push the bottom half of the switch after the engine has shut down to return the switch to the center.

Note: Restarting the engine after using the Emergency Stop switch may be slower or more difficult than normal starting.

- Sub throttle Control (Figure 12, (3)).
In the unlikely event that the throttle control fails, the Sub throttle indicator light will flash and the engine speed is controlled the Sub throttle. Engine speed rises when the Sub throttle knob is turned clockwise.

- When the Sub throttle indicator flashes, turn the Sub throttle knob counterclockwise to the end and turn the knob clockwise gradually until the Sub throttle indicator turns on (steady light).
- Each engine is controlled by a dedicated Sub throttle controller.

2nd Station Panel - Optional

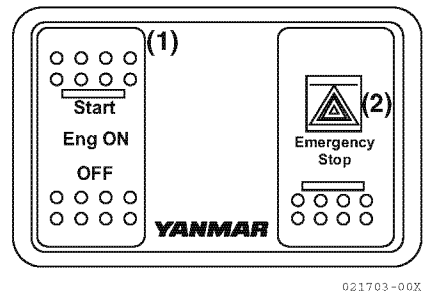

Figure 13

- The ignition switch (Figure 13, (1)) is wired to 1st station panel.
- Able to start and stop the engine from 2nd station panel.
- The Emergency Stop switch (Figure 13, (2)) is wired in series with 1st station panel.

PRODUCT OVERVIEW

Control Head Shift and Throttle Functions

Use the two-lever control head (Figure 14, (4)) in the helm station for AHEAD (Figure 14, (1)), ASTERN (Figure 14, (3)), NEUTRAL (Figure 14, (2)) and speed control in a twin installation.

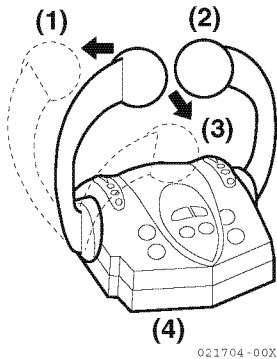

Figure 14

- 1 – Ahead**
- 2 – Neutral**
- 3 – Astern**
- 4 – Control Head**

Use the single-lever control head (Figure 15, (4)) in the helm station for AHEAD (Figure 15, (1)), ASTERN (Figure 15, (3)), NEUTRAL (Figure 15, (2)) and speed control in a single installation.

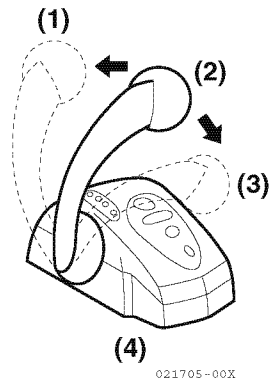

Figure 15

- 1 – Ahead**
- 2 – Neutral**
- 3 – Astern**
- 4 – Control Head**

Control Head Button Functions

- **N (or NEUTRAL) Button** – If the associated control head lever is in the “Neutral Idle” position, pushing this button engages / disengages Neutral Throttle control, allowing throttle but no forward or reverse thrust. If the associated control head lever is in a “Gear Idle” position, pushing this button engages / disengages Split Range Throttle (SRT) (if installed).
- **SELECT (or SEL) Button** – If the station is inactive, pushing this button activates the station (used in conjunction with two or more control stations).
- **SYNC Button** – Pushing this button engages / disengages the Cruise Synchronization option (if installed) when the port and starboard control head levers are set to nearly the same positions.

Control Head Operation

Selecting Active Station:

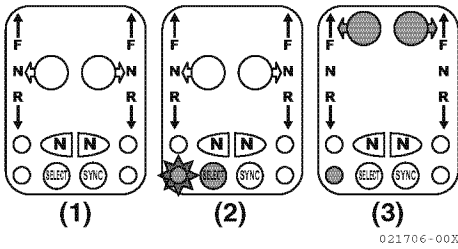

Figure 16

1. **(Figure 16, (1))** shows a typical inactive station.
2. Press the SELECT button **(Figure 16, (2))**. The button lights (grayed in **(Figure 16, (2))**) and the station select light flash (star around light in **(Figure 16, (2))**).
3. Move the handle(s) to forward or reverse throttle to match the handle location of the active station **(Figure 16, (3))**. The corresponding handle button lights (grayed in **(Figure 16, (3))**) and the station select light glow steadily (grayed in **(Figure 16, (3))**).

Engaging or Disengaging Shift Disconnect Mode:

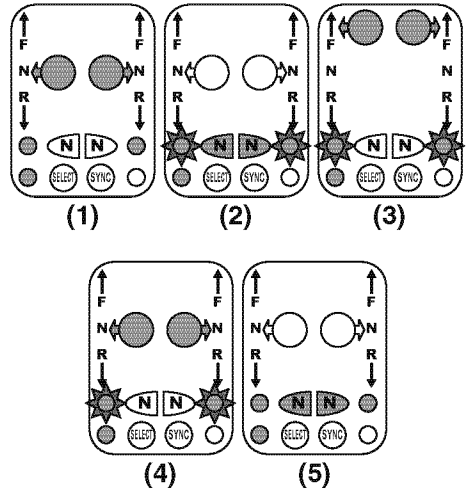

Figure 17

Engage:

1. Return the handle(s) to neutral. The N (NEUTRAL) lights glow steadily **(Figure 17, (1))**.
2. Press the NEUTRAL button(s) **(Figure 17, (2))**. The NEUTRAL light(s) flash (star around light(s) in **(Figure 17, (2))**).
3. Move the handle(s) to forward or reverse throttle **(Figure 17, (3))** resulting in engine rpm control without engaging marine gear.

Disengage:

1. Return the handle(s) to NEUTRAL **(Figure 17, (4))**.
2. Press the NEUTRAL button(s) **(Figure 17, (5))**. The neutral light(s) glow steady **(Figure 17, (5))**.

PRODUCT OVERVIEW

Engaging or Disengaging Split Range Throttle (SRT)

Note: Split Range Throttle is not available if the boat is equipped with the Trolling option.

The Split Range Throttle control head mode gives you greater throttle sensitivity. In Split Range Throttle (SRT), moving an engine's control lever all the way to the "Full Forward" position will only produce the maximum percentage of wide open throttle selected in the "Features Selection" of the ECU program options. Typical Throttle Limit percentages for SRT are 5% to 50%, with 25% being the default value.

3. If the system is shifted into neutral while in the Split Range Throttle engine mode, the N (NEUTRAL) lamp will come on (steady) to indicate that the system is in neutral. When the lever is moved back into gear, the N (NEUTRAL) lamp will resume flashing to indicate that the system is still in Split Range Throttle.

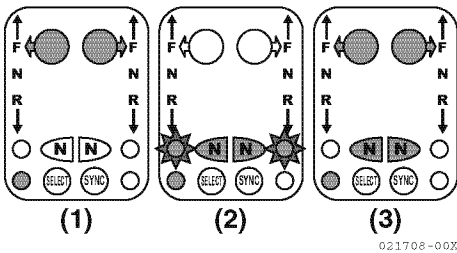

Figure 18

Engage:

1. Move the engine's lever to an in-gear idle position (Forward Idle or Reverse Idle) (**Figure 18, (1)**) and press the N (NEUTRAL) button (**Figure 18, (2)**) next to this lever on the control head. The N (NEUTRAL) lamp (**Figure 18, (2)**) will flash to indicate that the Split Range Throttle is engaged.
2. While in the Split Range Throttle, the system will shift normally but the throttle will be limited in both gears.

Disengage:

Return the engine lever to a Gear Idle position (Forward Idle or Reverse Idle) (**Figure 18, (3)**). Press the N (NEUTRAL) button next to the lever on the control head. The N (Neutral) lamp will stop flashing, indicating that the Split Range Throttle has been disengaged.

Engaging or Disengaging Cruise Synchronization:

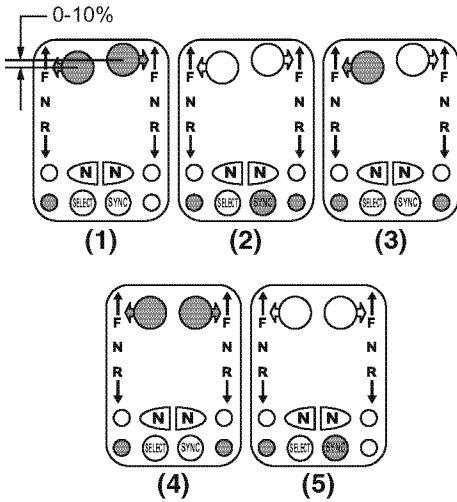

Figure 19

Engage:

1. Disengage any other engine mode being used.
2. Match all engine shift and throttle settings by moving the active port and starboard control head levers to within 5% of each other (**Figure 19, (1)**) and press the SYNC button (**Figure 19, (2)**) on the control head. The sync lamp flashes if the handles are not within 5% of each other (**Figure 19, (3)**). The sync lamp will stop flashing and remain continuously lit (**Figure 19, (4)**) when the levers are moved to within this 5% range.

A steady sync lamp confirms that the Cruise Sync is engaged. While the engines are synchronized, all engine speeds are matched any time the control levers are set to within 5% of each other and are above 20% throttle.

Disengage:

Press the SYNC button on the control head.

This Page Intentionally Left Blank

BEFORE YOU OPERATE

This section of the *Operation Manual* describes the diesel fuel, engine oil, and engine coolant specifications and how to replenish them. It also describes the daily engine checks.

Before performing any operations within this section, review the *Safety* section on page 3.

DIESEL FUEL

DANGER! *Diesel fuel is flammable and explosive under certain conditions. See Safety on page 3.*

Diesel Fuel Specifications

NOTICE: Only use diesel fuels recommended by Yanmar Marine for the best engine performance, to prevent engine damage and to comply with EPA warranty requirements. Only use clean diesel fuel.

Diesel fuel should comply with the following specifications. The table lists several worldwide specifications for diesel fuels.

DIESEL FUELSPECIFICATION	LOCATION
No. 2-D, No. 1-D, ASTM D975	USA
EN590:96	European Union
ISO 8217 DMX	International
BS 2869-A1 or A2	United Kingdom
JIS K2204 Grade No. 2	Japan

BEFORE YOU OPERATE

Bio-Diesel Fuels

Yanmar approves the use of biodiesel fuels that do not exceed a blend of 5% non-mineral oil based fuel with 95% standard diesel fuel. Such biodiesel fuels are known in the marketplace as B5 biodiesel fuels. B5 biodiesel fuel can reduce particulate matter and the emission of “greenhouse” gases compared to standard diesel fuel.

CAUTION! If the B5 biodiesel fuel used does not meet the approved specifications, it will cause abnormal wear of injectors, reduce the life of the engine and it may affect the warranty coverage of your engine.

B5 diesel fuels must meet certain specifications

The biodiesel fuels must meet the minimum specifications for the country in which they are used:

- In Europe, biodiesel fuels must comply with the European Standard EN14214.
- In the United States, biodiesel fuels must comply with the American Standard ASTM D-6751.

Biodiesel should be purchased only from recognized and authorized diesel fuel suppliers.

Precautions and concerns regarding the use of bio-fuels:

- Biodiesel fuels have a higher content of methyl-esters, which may deteriorate certain metal, rubber and plastic components of the fuel system. The customer and / or boat builder are responsible to verify the usage of biodiesel compatible components on the vessel fuel supply and return systems.
- Free water in biodiesel may result in plugging of fuel filters and increased bacterial growth.
- High viscosity at low temperatures may result in fuel delivery problems, injection pump seizures, and poor injection nozzle spray atomization.
- Biodiesel may have adverse effects on some elastomers (seal materials) and may result in fuel leakage and dilution of the engine lubricating oil.
- Even biodiesel fuels that comply with a suitable standard as delivered, will require additional care and attention to maintain the quality of the fuel in the equipment or other fuel tanks. It is important to maintain a supply of clean, fresh fuel. Regular flushing of the fuel system, and / or fuel storage containers, may be necessary.
- The use of biodiesel fuels that do not comply with the standards as agreed to by the diesel engine manufacturers and the diesel fuel injection equipment manufacturers, or biodiesel fuels that have degraded as per the precautions and concerns above, may affect the warranty coverage of your engine.

Additional Technical Fuel Requirements

- The fuel cetane number should be 45 or higher.
- The sulfur content must not exceed 0.5% by volume. Less than 0.05% is preferred.
- NEVER mix kerosene, used engine oil, or residual fuels with the diesel fuel.
- Water and sediment in the fuel should not exceed 0.05% by volume.
- Keep the fuel tank and fuel-handling equipment clean at all times.
- Ash content not to exceed 0.01% by volume.
- Carbon residue content not to exceed 0.35% by volume. Less than 0.1% is preferred.
- Total aromatics content should not exceed 35% by volume. Less than 30% is preferred.
- PAH (polycyclic aromatic hydrocarbons) content should be below 10% by volume.
- Do not use Biocide.
- Do not use kerosene or residual fuels.

Handling of Diesel Fuel

1. Water and dust in the fuel may cause engine failure. When fuel is stored, be sure that the inside of the storage container is clean and dry, and that the fuel is stored away from dirt or rain.

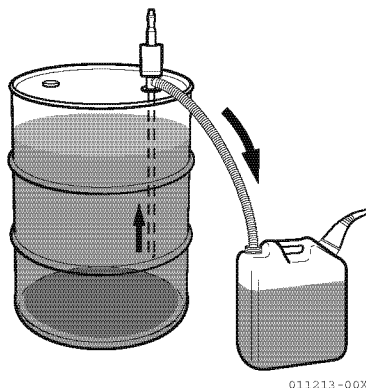

Figure 1

2. Keep the fuel container stationary for several hours to allow any dirt or water to settle to the bottom of the container. Use a pump to extract the clear, filtered fuel from the top of the container.

BEFORE YOU OPERATE

Fuel Tank (Not Supplied by Yanmar)

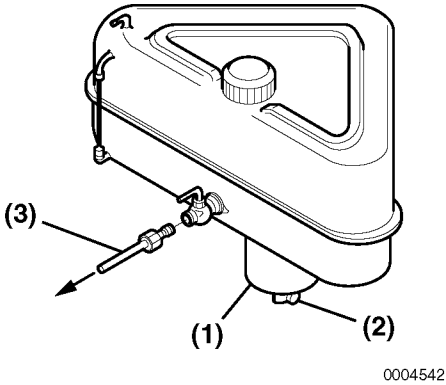

Figure 2

- 1 – Sediment Bowl
- 2 – Drain Cock
- 3 – Fuel Line to Engine

Install a drain cock (**Figure 2, (2)**) at the bottom of the fuel tank to remove water and contaminants from the sediment bowl (**Figure 2, (1)**).

The fuel outlet should be positioned 20 to 30 mm (0.8 to 1.2 in.) above the bottom of the tank so that only clean fuel is distributed to the engine.

Fuel System

Install the fuel line from the fuel tank to the fuel injection pump as shown in **Figure 3**. The recommended fuel / water separator (not supplied by Yanmar) is installed at the center section of that line.

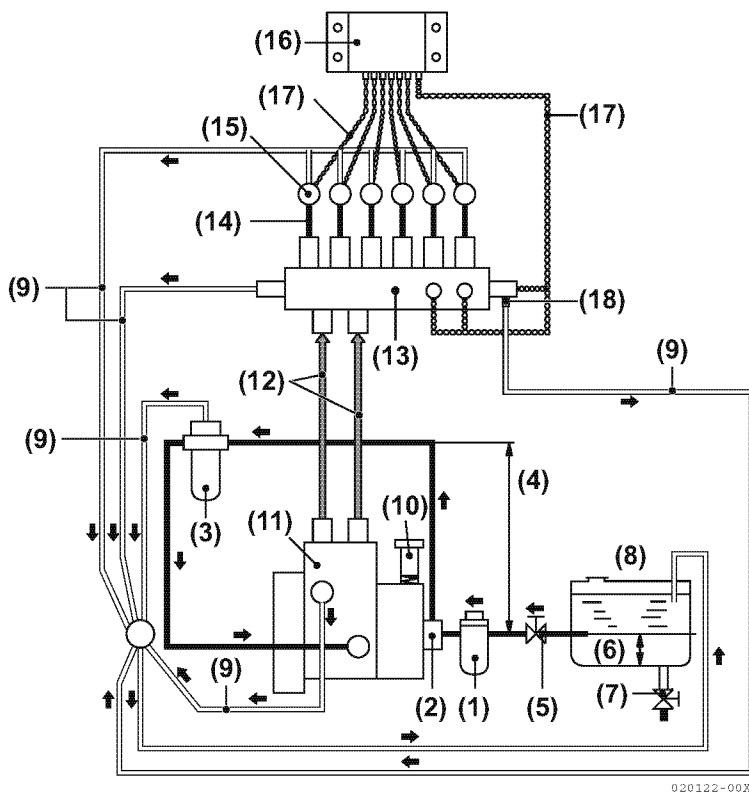

Figure 3

- | | |
|--|---|
| 1 – Fuel / Water Separator
(Not Supplied by Yanmar) | 10 – Fuel Priming Pump |
| 2 – Fuel Feed Pump | 11 – High-Pressure Fuel Pump |
| 3 – Fuel Filter | 12 – High-Pressure Supply Lines to
CR |
| 4 – Less than 500 mm (19.7 in.) | 13 – Common Rail (CR) |
| 5 – Fuel Cock | 14 – High-Pressure Fuel Lines |
| 6 – Approximately 20 to 30 mm
(0.8 to 1.2 in.) | 15 – Fuel Injector |
| 7 – Drain Cock | 16 – Electronic Drive Unit (EDU) for
Fuel System Control |
| 8 – Fuel Tank | 17 – Electric Control Cables |
| 9 – Fuel Return Lines | 18 – Pressure Relief Valve |

Filling the Fuel Tank

DANGER!

***NEVER refuel with the engine running.
See Safety on page 3.***

Before filling the fuel tank for the first time, rinse the fuel tank with kerosene or diesel fuel. Dispose of waste properly.

To fill the fuel tank:

NOTICE: Operate the bilge ventilation (blowers) for a minimum of 5 minutes to purge fumes from engine compartment after refueling. Never operate the bilge blower(s) while refueling. Doing so can pump explosive fumes into the engine compartment and result in an explosion.

1. Clean the area around the fuel cap.
2. Remove the fuel cap from the fuel tank.
3. Fill the tank with clean fuel free of oil and dirt. *NOTICE: Hold the hose nozzle firmly against the filler port while filling. This prevents static electricity buildup which could cause sparks and ignite fuel vapors.*
4. Stop fueling when the gauge shows the fuel tank is full. *NOTICE: NEVER overfill the fuel tank.*
5. Replace the fuel cap and hand-tighten. Over-tightening the fuel cap will damage it.

This Page Intentionally Left Blank

Bleeding the Fuel System

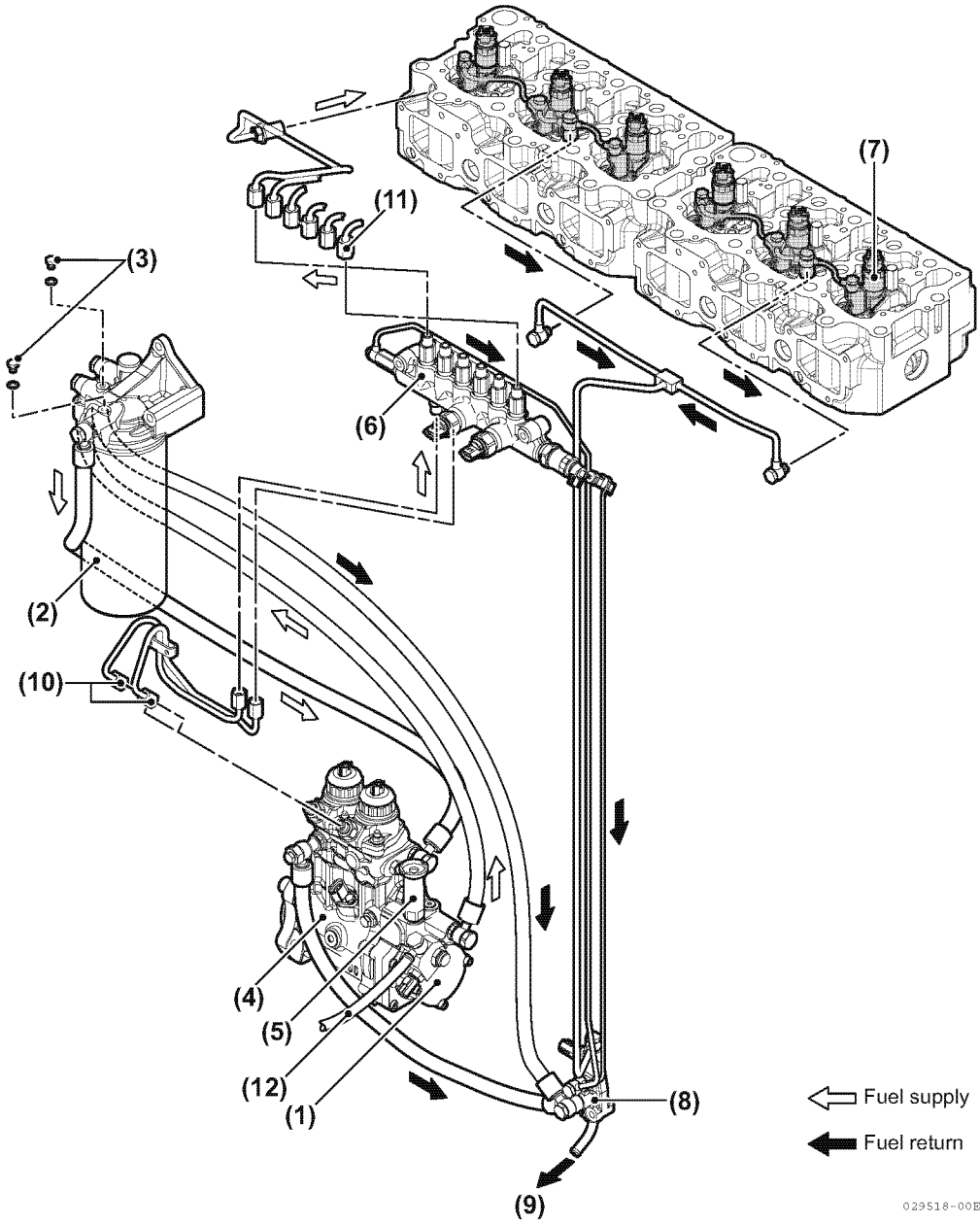

029518-00E

Figure 4

- 1 – Fuel Feed Pump**
- 2 – Fuel Filter**
- 3 – Air Bleed Screws**
- 4 – High-Pressure Fuel Supply Pump**
- 5 – Fuel Priming Pump**
- 6 – Common Rail (CR)**
- 7 – Fuel Injector**
- 8 – Fuel Return Joint**
- 9 – Fuel Return to Fuel Tank**
- 10 – High Pressure Fuel Line to Common Rail**
- 11 – Fuel Injection Line (No.6 Cylinder)**
- 12 – Fuel Inlet Line**

Fuel Bleeding Procedure

The initial fuel bleeding procedure after engine installation:

1. Check the fuel level in the fuel tank. Refill if necessary.
2. Open the fuel tank cock.
3. Loosen the air bleed screws ((**Figure 4, (5)**) and (**Figure 4, (12)**)) 2 - 3 turns. *NOTICE: Do not loosen the fuel lines.*
4. Open the fuel inlet valve.
5. Push the priming pump (**Figure 4, (7)**) until fuel flows from the air bleed screws (**Figure 4, (5)**) (about 200 times), then tighten the air bleed screws.
6. Start the engine using the starter motor.

Note: After engine start-up, the automatic air-bleeding device works to purge the air in the fuel system.

BEFORE YOU OPERATE

ENGINE OIL

Engine Oil Specifications

NOTICE: Using engine oil that does not meet or exceed the following guidelines or specifications may cause seizure of parts, abnormal wear and shorten engine life.

Service Categories

Use an engine oil that meets or exceeds the following guidelines and classifications:

- API Service Categories CD, CF, CF-4, CI, CI-4
- SAE Viscosity: 15W40. Engine oil 15W40 can be used throughout the year

NOTICE:

- *Be sure the engine oil, engine oil storage containers, and engine oil filling equipment are free of sediment or water.*
- *Change the engine oil after the first 50 hours of operation and then at every 250 hours thereafter.*
- *Yanmar does not recommend the use of engine oil "additives."*

Handling Engine Oil

1. When handling and storing engine oil, be careful not to allow dust and water to contaminate the oil. Clean around the filler port before filling.
2. Do not mix lubrication oils of different types or brands. Mixing may cause the chemical characteristics of the oil to change and lubricating performance to decrease, reducing the engine's life.
3. Engine oil should be replaced at the specified intervals, regardless if the engine has been operated.

Engine Oil Viscosity

SAE15W40 is the recommended oil viscosity.

If you operate your equipment below -15°C (5°F) or above 40°C (104°F), consult your authorized Yanmar Marine dealer or distributor for special lubricants or starting aids.

The 6CX530 engine has an oil filler port for each rocker arm cover and both sides of the oil pan, therefore there are a total of four oil filler ports.

The engine has a dipstick on both sides.

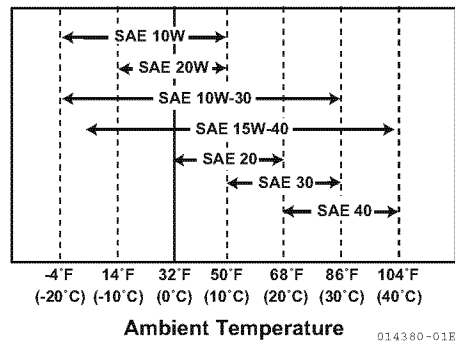
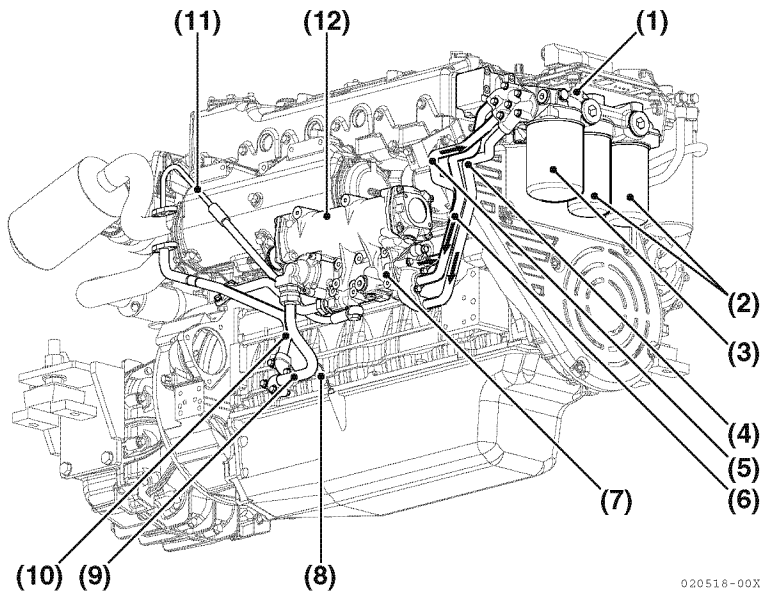

Figure 5

Engine Oil System



020516-00X

Figure 6

- | | |
|---|---|
| 1 – Oil Filter Manifold | 7 – Return Bypass |
| 2 – Full Flow Engine Oil Filters | 8 – Dipstick |
| 3 – Bypass Engine Oil Filter | 9 – Engine Oil Return |
| 4 – Bypass | 10 – Engine Oil Return from Turbocharger |
| 5 – Filter Inlet | 11 – Engine Oil Inlet to Turbocharger |
| 6 – Return Main | 12 – Engine Oil Cooler |

Engine Oil System (continued)

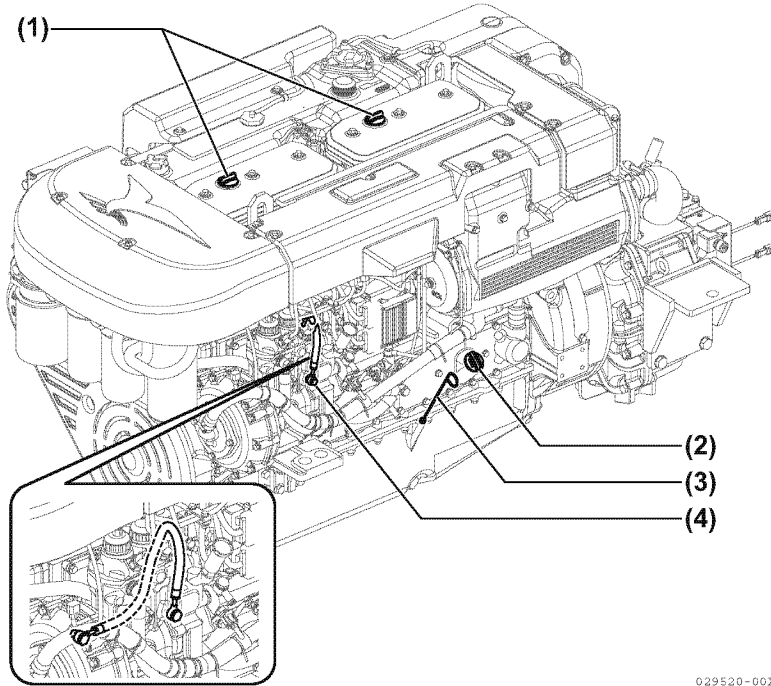

029520-00X

Figure 7

- 1 – Rocker Arm Cover Filler Caps**
- 2 – Oil Pan Filler Cap**

- 3 – Dipstick**
- 4 – Engine Oil Feed Pipe to High-Pressure Fuel Pump**

Checking the Engine Oil

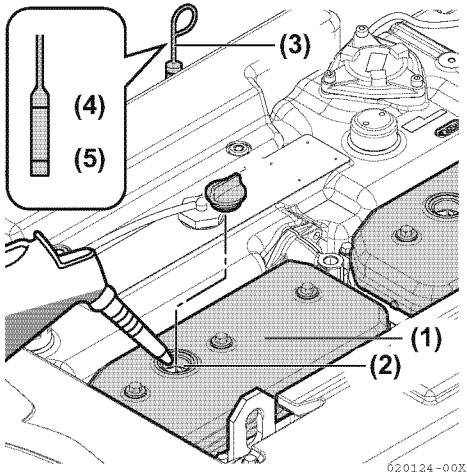

Figure 8

- 1 – Rocker Arm Cover
- 2 – Oil Filler Port
- 3 – Dipstick (Non-Operation Side)
- 4 – Upper Line
- 5 – Lower Line

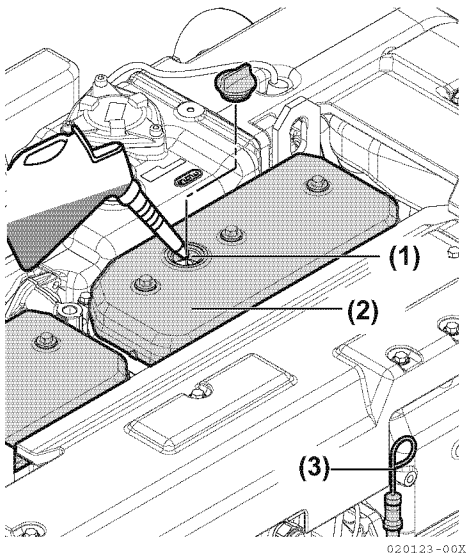

Figure 9

- 1 – Oil Filler Port
- 2 – Rocker Arm Cover
- 3 – Dipstick (Operation Side)

1. Make sure the engine is level.
2. Remove dipstick (**Figure 8, (3)**) or (**Figure 9, (3)**) and wipe with clean cloth.
3. Fully reinsert dipstick.
4. Remove dipstick. The oil level should be between upper (**Figure 8, (4)**) and lower (**Figure 8, (5)**) lines on the dipstick.
5. Add oil if necessary. See *Adding Engine Oil* on page 40.
6. Fully reinsert dipstick.

Adding Engine Oil

1. **NOTICE:** Prevent dirt and debris from contaminating the engine oil. Carefully clean the dipstick and the surrounding area before you remove the cap. Remove the yellow oil filler port cap from filler port (**Figure 8, (2)**) or (**Figure 9, (1)**) and fill with engine oil.
2. Fill with oil to the upper limit (**Figure 8, (4)**) on the dipstick (**Figure 8, (3)**) or (**Figure 9, (3)**).
NOTICE: NEVER overfill the engine with engine oil.
3. Insert the dipstick fully to check the level. **NOTICE:** ALWAYS keep the oil level between upper and lower lines on the oil cap / dipstick.
4. Hand-tighten the filler port cap securely.

MARINE GEAR OIL

Marine Gear Oil Specifications

Use marine gear oil that meets or exceeds the following guidelines and classifications:

KMH70A:

- API Service Categories CD, CF or higher
- SAE Viscosity or #30

Checking the Marine Gear Oil

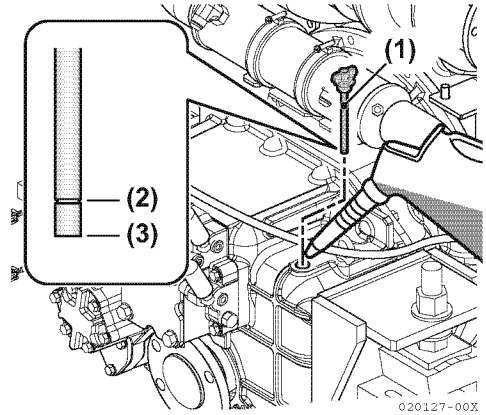

Figure 10

- 1 – Dipstick (Marine Gear Oil)**
- 2 – High Level**
- 3 – Lower Level**

Note: 6CX530 with KMH70A marine gear shown.

1. Make sure engine is level.
2. **NOTICE:** Prevent dirt and debris from contaminating the marine gear oil. Carefully clean the filler cap / dipstick and the surrounding area before you remove the filler cap / dipstick. Remove filler cap / dipstick (**Figure 10, (1)**) and wipe with clean cloth.
3. Fully reinsert dipstick.

4. Remove dipstick. The oil level should be between upper (**Figure 10, (2)**) and lower (**Figure 10, (3)**) lines on the dipstick. *NOTICE: ALWAYS keep the marine gear oil level between the upper and lower lines on the dipstick.*
5. Fully reinsert dipstick.

Adding Marine Gear Oil

1. Make sure the engine is level.
2. Remove the filler cap / dipstick (**Figure 10, (1)**) at the top of the housing.
3. Fill with oil to the upper limit on the dipstick (**Figure 10, (2)**). See *Marine Gear Oil Specifications* on page 40. *NOTICE: NEVER overfill the marine gear with oil.*
4. Fully reinsert dipstick.
5. Tighten the filler port cap by hand.

ENGINE COOLANT

Engine Coolant Specifications

- Texaco Long Life Coolant (LLC), both standard and premixed, product code 7997 and 7998
- Havoline Extended Life Antifreeze / Coolant, product code 7994

Note: In the U.S., LLC is required for the warranty to be valid.

NOTICE: Following the manufacturer's recommendations, use a proper LLC which will not have any adverse effects on the materials (cast iron, aluminum, copper, etc.) of the engine's cooling system. See Engine Coolant Specifications on page 33.

ALWAYS use the mixing ratios specified by the antifreeze manufacturer for the temperature range.

Coolant (Closed Cooling System)

NOTICE: ALWAYS add LLC to soft water – especially when operating in cold weather. NEVER use hard water. Water should be clean and free from sludge or particles. Without LLC, cooling performance will decrease due to scale and rust in the coolant system. Water alone may freeze and form ice; it expands approximately 9% in volume. Use the proper amount of coolant concentrate for the ambient temperature as specified by the LLC manufacturer. LLC concentration should be a minimum of 30% to a maximum of 60%. Too much LLC will decrease the cooling efficiency. Excessive use of antifreeze also lowers the cooling efficiency of the engine. NEVER mix different types or brands of LLC, as a harmful sludge may form. Mixing different brands of antifreeze may cause chemical reactions, and may make the antifreeze useless or cause engine problems.

BEFORE YOU OPERATE

Checking and Adding Coolant

NOTICE: The 6CX530 engine has two coolant tank filler ports. This is to provide accessibility due to marine gear application. The black filler cap indicates the primary filler port that should be used. The aluminum filler cap indicates the spare filler cap. The coolant tank is equipped with a coolant level sensor. If the coolant level is low, an alarm is illuminated on the instrument panel.

1. Ensure all drain cocks are closed.

Note: The drain cocks are opened before shipping from the factory.

2. Loosen the filler cap (**Figure 11, (1)**) of the coolant tank to relieve the pressure, then remove the filler cap. **WARNING! NEVER remove the coolant filler cap if the engine is hot. Steam and hot engine coolant will spray out and seriously burn you. Allow the engine to cool down before you attempt to remove the cap.**

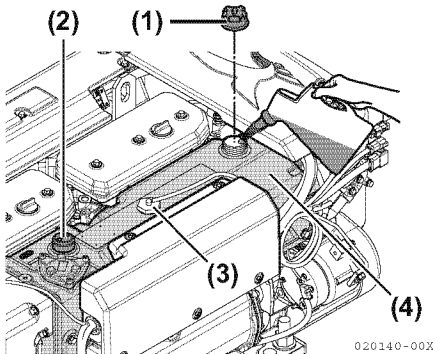

Figure 11

- 1 – Coolant Filler Cap
- 2 – Cap (Spare Filler Port)
- 3 – Coolant Level Sensor
- 4 – Coolant Tank

3. **NOTICE: NEVER pour cold coolant into a hot engine.** Pour coolant slowly into the coolant tank (**Figure 11, (4)**) to avoid air bubbles. Fill until coolant overflows from the filler port.

Coolant Tank Capacity
28 L (7.4 Gal)

4. Tighten filler cap.

WARNING! ALWAYS tighten the coolant tank cap securely after checking the coolant tank. Steam can spray out during engine operation if the cap is loose.

Note: The coolant level rises in the coolant recovery tank during operation. After stopping the engine, the coolant will cool down and the extra coolant will return to the coolant tank.

5. Check the coolant level in the coolant recovery tank. The level should be at the FULL mark (**Figure 12, (2)**). Add coolant if necessary. **NOTICE: NEVER pour cold coolant into a hot engine.**

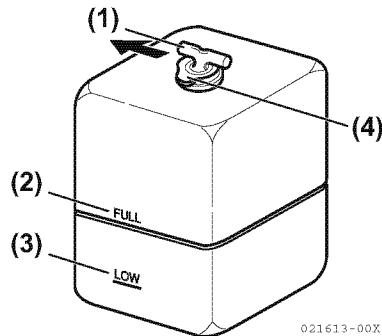

Figure 12

6. Remove coolant recovery tank cap (**Figure 12, (4)**) to add coolant if necessary. Do not add water.
7. Replace filler cap and tighten it firmly. Failure to do so will cause water leakage.

Coolant Recovery Tank Capacity
3.4L (7.2 pt)

8. Check the rubber hose (**Figure 12, (1)**) connecting the coolant recovery tank to the coolant tank / heat exchanger. Replace if damaged.

Note: If the coolant runs low too often or only the coolant level in the coolant tank drops without any change in the level in the coolant recovery tank, there may be water or air leaks in the cooling system. See your authorized Yanmar Marine dealer or distributor.

CHECKING THE ENGINE OIL AND ENGINE COOLANT

When engine oil or coolant is supplied for the first time or when they must be replaced, conduct a trial operation of the engine for about 5 minutes and check the quantity of engine oil and coolant. The trial engine operation will send the engine oil and coolant to the passages, so the engine oil and coolant levels will drop. Check and resupply as necessary:

1. Approximately 10 minutes after stopping the engine, remove the oil dipstick (**Figure 9, (3)**) and check the oil level. Add oil if the level is too low.
2. Add coolant to the coolant recovery tank to stay within the upper or lower limit ((**Figure 12, (2)**) and (**Figure 12, (3)**)).

This Page Intentionally Left Blank

ENGINE OPERATION

This section of the *Operation Manual* describes the diesel fuel, engine oil, and engine coolant specifications and how to replenish them. It also describes the daily engine checkout.

Before performing any operations within this section, review the *Safety* section on page 3.

WARNING

Fire and Explosion Hazard



NEVER jump-start the engine. Sparks caused by shorting the battery to the starter terminals may cause a fire or explosion. ONLY use the key switch to start the engine.

Sudden Movement Hazard

Be sure the boat is in open water away from other boats, docks or other obstructions before increasing rpm. Avoid unexpected equipment movement. Shift the marine gear into the NEUTRAL position any time the engine is at idle.

To prevent accidental equipment movement, NEVER start the engine in gear.

Sever Hazard



Before you start the engine make sure that all bystanders are clear of the area. Keep children and pets away while the engine is operating.

Exhaust Hazard



NEVER block windows, vents or other means of ventilation if the engine is operating in an enclosed area. All internal combustion engines create carbon monoxide gas during operation and special precautions are required to avoid carbon monoxide poisoning.

NOTICE

If you have an installation with two or three engines, and only one engine is operating, please note that if the propeller shaft thru-hull (stuffing box) is lubricated by engine water pressure and the engines are interconnected, care must be taken that water from the running engine does not enter the exhaust of the non-running engine(s). This water could cause seizure of the non-running engine(s). See your authorized Yanmar Marine dealer or distributor for a complete explanation of this condition..

If you have an installation with two or three engines, and only one engine is operating, the water pickup (thru-hull) of the non-running engine(s) should be closed. This will prevent water from being forced past the seawater pump and eventually finding its way into the engine. The result of water entering the engine could cause seizure or other serious problems.

If you have an installation with two or three engines, and only one engine is operating, it is important to limit the amount of throttle applied to the running engine. If you observe black smoke or movement of the throttle does not increase engine rpm, you are overloading the engine that is running. Immediately throttle back to approximately 2/3 throttle or to a setting where the engine performs normally. Failure to do so may cause the running engine to overheat or cause excess carbon buildup which may shorten the engine's life.

NOTICE

New Engine Break In: On the initial engine start-up, check for proper engine oil pressure, diesel fuel leaks, engine oil leaks, coolant leaks, and for proper operation of the indicators and / or gauges. During the first 50 hours of operation operate your new engine under a substantial load at all times. For best break-in results operate the engine at various speeds. Operating the engine in NEUTRAL must be avoided. During the first 50 hours, avoid operation below 2000 rpm. During the break-in period, carefully observe the engine oil pressure and engine temperature. During the break-in period, check the engine oil and coolant levels frequently.

If any indicator illuminates during engine operation, stop the engine immediately. Determine the cause and repair the problem before you continue to operate the engine. If the alarm window with audible alarm fails to display and go out about 3 seconds later when the ignition switch is in the ON position, see your authorized Yanmar Marine dealer or distributor for service before operating the engine.

Observe the following environmental operating conditions to maintain engine performance and avoid premature engine wear:

- Avoid operating in extremely dusty conditions.
- Avoid operating in the presence of chemical gases or fumes.
- NEVER run the engine if the ambient temperature is above +40°C (+104°F) or below -16°C (+3°F).
- If the ambient temperature exceeds +40°C (+104°F), the engine may overheat and cause the engine oil to break down.
- If the ambient temperature is below -16°C (+3°F), rubber components such as gaskets and seals will harden causing premature engine wear and damage.
- Contact your authorized Yanmar Marine engine dealer or distributor if the engine will be operated outside of this standard temperature range.

NEVER engage the starter motor while the engine is running. Damage to the starter motor pinion and / or ring gear will result.

STARTING THE ENGINE

Before Starting the Engine

1. Open the seacock.
2. Open the fuel tank cock.
3. Set the control lever on the control head (Figure 1, (2)) in N (NEUTRAL) (Figure 1, (1)) position.

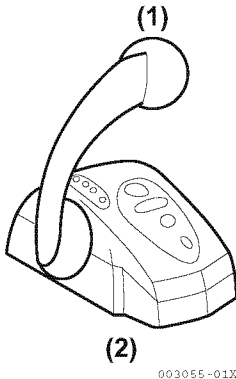

Figure 1

4. Turn the battery switch on, and the screen (Figure 2) pops up on the display. Then the screen will change to the engine data display mode.



Figure 2

5. Press the ignition switch (Figure 3, (1)) and the following change occurs:

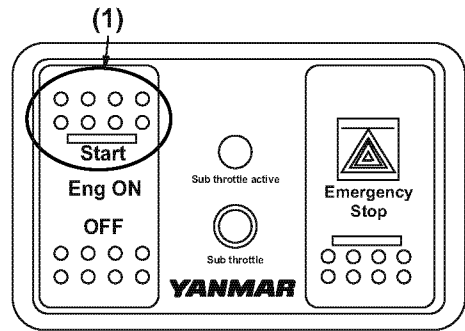

Figure 3

The needle appears in the engine tachometer on the display.

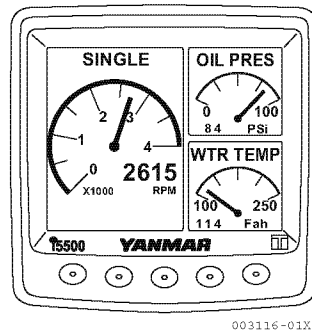

Figure 4

Starting the Engine

To start the engine, press Start (upper half) of ignition switch (Figure 3, (1)).

If the Engine Fails to Start

NOTICE: NEVER hold the key in the Start position for longer than 15 seconds or the starter motor will overheat.

Before pressing the Start switch again, confirm that the engine has stopped completely. If the starter motor is operated before the engine has completely stopped, the starter motor pinion gear will be damaged.

NOTICE: Hold the Start switch for a maximum of 15 seconds in the START position. If the engine does not start the first time, press the rocker switch OFF and wait for about 15 seconds before trying again. After the engine has started, do not press the rocker switch OFF. (It should remain on.)

NOTICE: If the vessel is equipped with a water lift (water lock) muffler, excessive cranking could cause seawater to enter the cylinders and damage the engine. If the engine does not start after cranking 15 seconds, close the thru-hull water intake valve to avoid filling the muffler with water. Crank for 15 seconds or until the engine starts. When the engine does start, stop the engine immediately and press the switch to the OFF position. Be sure to re-open the seacock and restart the engine. Operate the engine normally.

After the Engine has Started

After the engine has started, check the following items at a low engine speed:

1. Check that the indicators on the display and the control head are normal.
2. Check for water or oil leakage from the engine.
3. Check that exhaust color, engine vibrations, and sound are normal.
4. When there are no problems, keep the engine at low speed to send engine oil to all parts of the engine.

5. Check that sufficient seawater is discharged from the seawater outlet pipe. Operation with inadequate seawater discharge will damage the impeller of the seawater pump. If seawater discharge is too small, stop the engine immediately. Identify the cause and repair.

- Is the seacock open?
- Is the inlet of the seacock on the hull bottom clogged?
- Is the seawater suction hose broken, or does the hose suck in air due to a loose joint?

Note: The engine will seize if it is operated when seawater discharge is too small or if load is applied without any warming up operation.

Shifting

WARNING! SUDDEN MOVEMENT HAZARD! The boat will start to move when the marine gear is engaged:

- Ensure the boat is clear of all obstacles forward and aft.
- Quickly shift to the **FORWARD** position then back to the **NEUTRAL** position.
- Observe whether the boat moves in the direction you expect.

Neutral

Be sure to set the control lever at N (NEUTRAL) position (**Figure 5, (1)**).

Note: Clutch operation or the use of trolling during high speed will cause internal parts of the clutch to break or to wear excessively.

1. Before using the marine gear, be sure to move the control lever (throttle) to a low idle position (the detent position). Then move the control lever slowly to a higher speed position after completing clutch engagement.
2. When changing between FORWARD and REVERSE, bring the clutch to NEUTRAL and pause before slowly shifting to the desired position. Do not shift abruptly from FORWARD to REVERSE or vice versa.
3. Move the control lever accurately and fully into the FORWARD, NEUTRAL, and REVERSE positions.

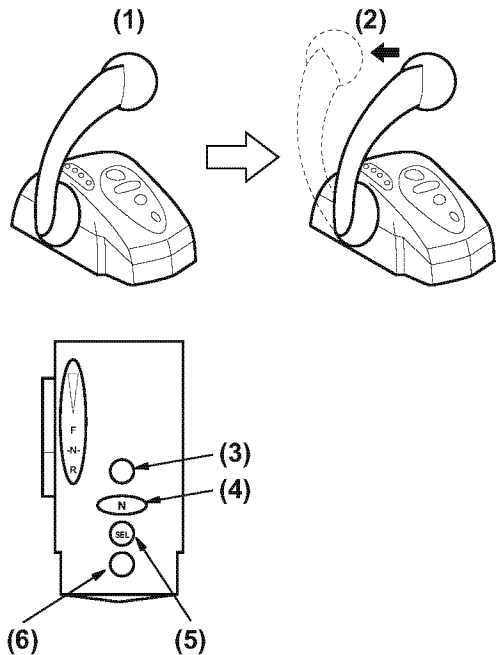

003117-01X

Figure 5

Ahead

Gradually move the control lever in the F (forward) direction (**Figure 5, (2)**) to the position of the Forward Detent. The marine gear will shift into FORWARD. The engine will remain at idle. Pushing further on the control lever will increase the rpm up to a maximum of wide open throttle (WOT).

Astern

Gradually move the control lever in the R (reverse) direction to the position of the Reverse Detent. The marine gear will shift into REVERSE. The engine will remain at idle. Pulling further on the control lever will increase the rpm up to a maximum of wide open throttle (WOT).

CAUTIONS DURING OPERATION

Note: Engine trouble can arise if the engine is operated for a long time under overloaded conditions with the control lever in the full throttle position (maximum engine speed position), exceeding the continuous rated output engine speed. Operate the engine at about 100 rpm lower than the full throttle engine speed.

Note: If the engine is in the first 50 hours of operation, see *New Engine Break-In* on page 12.

Always be on the lookout for problems during engine operation.

Pay particular attention to the following:

1. Is sufficient seawater being discharged from the exhaust and seawater outlet pipe?

If the discharge is small, stop the engine immediately; identify the cause and repair.

2. Is the exhaust color normal?

The continuous emission of black exhaust smoke indicates engine overloading. This shortens the engine's life and should be avoided.

3. Are there abnormal vibrations or noise?
CAUTION! Excessive vibration may cause damage to the engine, marine gear, hull and onboard equipment. In addition, it causes noticeable passenger and crew discomfort.

Depending on the hull structure, engine and hull resonance may suddenly become great at a certain engine speed range, causing heavy vibrations. Avoid operation in this speed range. If you hear any abnormal sounds, stop the engine and inspect.

4. Alarm buzzer sounds during operation.
NOTICE: If any alarm indicator with audible alarm sound appears on the display during engine operation, stop the engine immediately. Determine the cause and repair the problem before you continue to operate the engine.

5. Is there water, oil, or fuel leakage, or are there any loose bolts? Check the engine room periodically for any problems.

6. Is there sufficient diesel fuel in the diesel fuel tank? Replenish diesel fuel before leaving the dock to avoid running out of fuel during operation.

7. When operating the engine at low speed for long periods of time, race the engine once every 2 hours.

Note: Racing the engine: With the gear in NEUTRAL, accelerate from the low speed position to the high speed position and repeat this process about 5 times. This is done to clean out carbon from the cylinders and the fuel injection valve. Neglecting to race the engine will result in poor exhaust color and reduce engine performance.

8. If possible, periodically operate the engine at near maximum rpm, while underway.

This will generate higher exhaust temperatures, which will help clean out hard carbon deposits, maintaining engine performance and prolonging the life of the engine. *NOTICE: NEVER turn off the battery switch (if equipped) or short the battery cables during operation. Damage to the electric system will result.*

SHUTTING DOWN THE ENGINE

Stop the engine in accordance with the following procedures:

Normal Shutdown

1. Return the control lever to NEUTRAL position. (The N light turns on.)
2. Cool the engine down at low speed (below 1000 rpm) for about 5 minutes. **CAUTION! For maximum engine life, Yanmar recommends that when shutting the engine down, you allow the engine to idle, without load, for 5 minutes. This will allow the engine components that operate at high temperatures, such as the turbocharger (if equipped) and exhaust system, to cool slightly before the engine itself is shutdown.**
3. Push OFF (bottom half) of ignition switch (**Figure 6, (3)**).
4. Turn the battery switch off.
5. Close the fuel tank cock.
6. Close the seacock. **CAUTION! Be sure to close the seacock. Neglecting to close the seacock could allow water to leak into the boat and may cause it to sink. CAUTION! If seawater is left inside the engine, it may freeze and damage parts of the cooling system when the ambient temperature is below 0°C (32°F).**

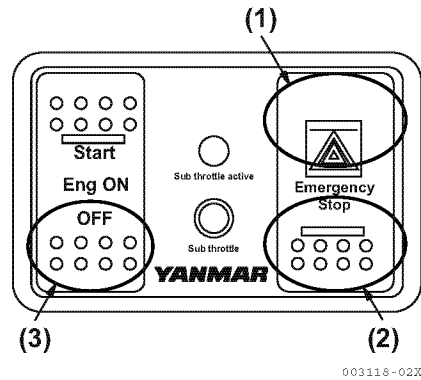

Figure 6

Emergency Shutdown

Electric Emergency Stop:

CAUTION! NEVER use the Emergency Stop switch for a normal engine shutdown. Use this switch only when stopping the engine suddenly in an emergency.

Push the upper part of Emergency Stop switch (**Figure 6, (1)**) on the right of the panel and the engine shuts down immediately, without the time lag of regular engine shutdown. After shutdown push the bottom part of the emergency stop switch (**Figure 6, (2)**) to be returned to the former position.

IMPORTANT! Use this switch only in an emergency. Under normal circumstances, use the OFF, ON, START switch (**Figure 6, (1)**) to stop the engine.

Note: Restarting the engine after using the emergency stop may be slower or more difficult than normal starting.

CHECKING THE ENGINE AFTER OPERATION

- Check that the key switch is in the OFF position and battery master switch (if equipped) is turned to OFF.
- Fill the fuel tank. *See Filling the Fuel Tank on page 32.*
- Close seawater cock(s).
- If there is a risk of freezing, check that the cooling system contains enough coolant. *See Engine Coolant Specifications on page 41*
- If there is a risk of freezing, drain the seawater system. *See Draining the Seawater Cooling System on page 84.*
- At temperatures below 0°C (32°F), drain seawater system and connect the engine heater (if equipped).

This Page Intentionally Left Blank

PERIODIC MAINTENANCE

This section of the *Operation Manual* describes the procedures for proper care and maintenance of the engine.

Before performing any maintenance procedures within this section, read the following safety information and review the *Safety* section on page 3.

SAFETY PRECAUTIONS

WARNING

Crush Hazard



If the engine needs to be transported for repair, have a helper assist you attach it to a hoist and load it on a truck.

The engine lifting eyes are engineered to lift the weight of the marine engine only. **ALWAYS** use the engine lifting eyes when lifting the engine.

Additional equipment is necessary to lift the marine engine and marine gear together. **ALWAYS** use lifting equipment with sufficient capacity to lift the marine engine.

WARNING

Welding Hazard

ALWAYS turn off the battery switch (if equipped) or disconnect the negative battery cable and the leads to the alternator when welding on the equipment.

Remove the engine control unit multi-pin connector. Connect the weld clamp to the component to be welded and as close as possible to the welding point.

NEVER connect the weld clamp to the engine or in a manner which would allow current to pass through a mounting bracket.

When welding is completed, reconnect the alternator and engine control unit prior to reconnecting the batteries.

Exhaust Hazard



ALWAYS ensure that all connections are tightened to specifications after repair is made to the exhaust system.

All internal combustion engines create carbon monoxide gas during operation and special precautions are required to avoid carbon monoxide poisoning.

Shock Hazard



ALWAYS turn off the battery switch (if equipped) or disconnect the negative battery cable before servicing the equipment.

ALWAYS keep the electrical connectors and terminals clean. Check the electrical harnesses for cracks, abrasions, and damaged or corroded connectors.

NEVER use undersized wiring for the electrical system.

Sever Hazard

Check the engine that any tools or shop rags used during maintenance have been removed from the area.

NOTICE

Any part which is found defective as a result of inspection, or any part whose measured value does not satisfy the standard or limit, must be replaced.

Modifications may impair the engine's safety and performance characteristics and shorten the engine's life. Any alterations to this engine may void its warranty. Be sure to use Yanmar genuine replacement parts.

PRECAUTIONS**The Importance of Periodic Maintenance**

Engine deterioration and wear occur in proportion to the length of time the engine has been in service and the conditions the engine is subjected to during operation. Periodic maintenance prevents unexpected downtime, reduces the number of accidents due to poor machine performance and helps extend the life of the engine.

Performing Periodic Maintenance

WARNING! NEVER block windows, vents, or other means of ventilation if the engine is operating in an enclosed area. All internal combustion engines create carbon monoxide gas during operation. Accumulation of this gas within an enclosure could cause illness or even death. Make sure that all connections are tightened to specifications after repair is made to the exhaust system. Failure to comply could result in death or serious injury.

The Importance of Daily Checks

The Periodic Maintenance Schedule assumes that the daily checks are performed on a regular basis. Make it a habit of performing daily checks before the start of each operating day. See *Daily Checks* on page 65.

Keep a Log of Engine Hours and Daily Checks

Keep a log of the number of hours the engine is run each day and a log of the daily checks performed. Also note the date, type of repair (e.g., replaced alternator), and parts used for any service needed between the periodic maintenance intervals. Periodic maintenance intervals are every 50, 250, 500, and 1000 engine hours. Failure to perform periodic maintenance will shorten the life of the engine. *NOTICE: Failure to perform periodic maintenance will shorten the life of the engine and may void the warranty.*

Yanmar Replacement Parts

Yanmar recommends that you use genuine Yanmar parts when replacement parts are needed. Genuine replacement parts help ensure long engine life.

Tools Required

Before you start any periodic maintenance procedure, make sure you have the tools you need to perform all of the required tasks.

Ask Your Authorized Yanmar Marine Dealer or Distributor for Help

Our professional service technicians have the expertise and skills to help you with any maintenance or service related procedures you need help with.

Tightening Fasteners

Use the correct amount of torque when you tighten fasteners on the machine. Applying excessive torque may damage the fastener or component and not enough torque may cause a leak or component failure.



NOTICE: *The tightening torque in the Standard Torque Chart should be applied only to the bolts with a “7” head (JIS strength classification: 7T). Apply 60% torque to bolts that are not listed. Apply 80% torque when tightened to aluminum alloy.*

Bolt diameter x pitch (mm)		M6x1.0	M8x1.25	M10x1.5	M12x1.75	M14x1.5	M16x1.5
Tightening Torque	N-m	11.0 ± 1.0	25.0 ± 2.9	49.0 ± 4.9	88.0 ± 10.0	140.0 ± 10.0	230.0 ± 10.0
	kgf-m	1.1 ± 0.1	2.5 ± 0.3	5.0 ± 0.5	9.0 ± 1.0	14.3 ± 1.0	23.5 ± 1.0
	lb-ft	8.1 ± 0.1	18.4 ± 2.1	36.1 ± 3.6	64.9 ± 7.4	103.3 ± 7.4	169.6 ± 7.4
	lb-in.	97.4 ± 8.9	–	–	–	–	–

EPA MAINTENANCE REQUIREMENTS

To maintain optimum engine performance and compliance with the Environmental Protection Agency (EPA) Regulations for Engines, it is essential that you follow the *Periodic Maintenance Schedule on page 61* and the *Periodic Maintenance Procedures on page 65*.

EPA Requirements for USA and Other Applicable Countries

The following are the requirements for the EPA. Unless these requirements are met, the exhaust gas emissions will not be within the limits specified by the EPA.

See Conditions to Ensure Compliance with EPA Emission Standards on page 60. Clean or replace the air cleaner element if the air intake restriction exceeds the referenced specifications.

EPA Requirements

The EPA emission regulation is applicable only in the USA and other countries that have adapted the EPA requirements in part or in whole. Determine and follow the emission regulations in the country where your engine will be operating to assist you in specified compliance.

Conditions to Ensure Compliance with EPA Emission Standards

The 6CX530 is an EPA-certified engine.

The following are the conditions that must be met in order to ensure that the emissions during operation meet the EPA standards.

The operating conditions should be as follows:

- Ambient temperature: -20° to +40°C (-4° to +104°F)
- Relative humidity: 80% or lower

The diesel fuel should be:

- ASTM D975 No. 1-D or No. 2-D, or equivalent (minimum cetane No. 45)

The lubricating oil should be:

- Type API, Class CD, CF, CF-4, CI, CI-4

Be sure to perform inspections as outlined in *Periodic Maintenance Procedures on page 65* and keep a record of the results.

Pay particular attention to these important points:

- Replacing the engine oil
- Replacing the engine oil filter
- Replacing the fuel filter
- Cleaning the intake silencer (air cleaner)

Note: Inspections are divided into two sections in accordance with who is responsible for performing the inspection: the user or the maker.

Inspection and Maintenance

See Inspection and Maintenance of EPA Emission-Related Parts on page 64 for the EPA emission-related parts. Inspection and maintenance procedures not shown in the *Inspection and Maintenance of EPA Emission-Related Parts* section are covered in *Periodic Maintenance Schedule on page 61*.

This maintenance must be performed to keep the emission values of your engine in the standard values during the warranty period. The warranty period is determined by the age of the engine or the number of hours of operation.

PERIODIC MAINTENANCE SCHEDULE

Daily and periodic maintenance is important to keep the engine in good operating condition. The following is a summary of maintenance items by periodic maintenance intervals. Periodic maintenance intervals vary depending on engine application, loads, diesel fuel and engine oil used and are hard to establish definitively. The following should be treated only as a general guideline.

CAUTION! *Establish a periodic maintenance plan according to the engine application and make sure to perform the required periodic maintenance at the intervals indicated. Failure to follow these guidelines will impair the engine's safety and performance characteristics, shorten the engine's life and may affect the warranty coverage on your engine. See your authorized Yanmar Marine dealer or distributor for assistance when checking items marked with a ●.*

PERIODIC MAINTENANCE

○: Check or Clean ◇: Replace ●: Contact your authorized Yanmar Marine dealer or distributor							
System	Item	Periodic Maintenance Interval					
		Daily See Daily Checks on page 65.	Every 50 hours or monthly whichever comes first	Every 250 hours or one year whichever comes first	Every 500 hours or two years whichever comes first	Every 1000 hours or four years whichever comes first	
Whole	Visual inspection of engine exterior	○					
Fuel System	Check fuel level and refill if necessary	○					
	Drain water and sediment from fuel tank		○ Initial 50	○			
	Drain fuel filter / water separator		○				
	Replace fuel filter element			◇			
	Replace fuel primary filter (if equipped)			◇			
	Check the fuel injection timing					●	
	Check fuel injector spray pattern*					●*	
Lubricating System	Check engine oil level	Engine	○				
		Marine Gear	○				
	Replace engine oil	Engine		◇ Initial 50	◇		
		Marine Gear		◇ Initial 50	◇		
	Replace oil filter element	Engine		◇ Initial 50	◇		
	Clean the Oil Strainer	Marine Gear (if equipped)		○ Initial 50	○		
Cooling System	Seawater outlet		○ During Operation				
	Check coolant level		○				
	Check or replace seawater pump impeller				○	◇	
	Replace coolant	Every year. When Long Life Coolant is used, replace every two years. See Engine Coolant Specifications on page 41.					
	Clean and check seawater passages					●	
	Replace zinc anode				◇		

PERIODIC MAINTENANCE

1207

○: Check or Clean ◇: Replace ●: Contact your authorized Yanmar Marine dealer or distributor						
System	Item	Periodic Maintenance Interval				
		Daily See Daily Checks on page 65.	Every 50 hours or monthly whichever comes first	Every 250 hours or one year whichever comes first	Every 500 hours or two years whichever comes first	Every 1000 hours or four years whichever comes first
Air Intake and Exhaust System	Clean intake air filter			○		
	Clean or replace exhaust / water mixing elbow			○		◇
	Clean turbocharger*			●		
Electrical System	Check alarm and indicators	○				
	Check electrolyte level in the battery		○			
	Adjust tension of the alternator belt or replace belt		○ Initial 50	○		◇
	Check wiring connectors			○		
Engine Cylinder Head and Block	Check for leakage of fuel, engine oil and engine coolant	○ After starting				
	Tighten all major nuts and bolts			●		
	Adjust intake / exhaust valve clearance		● Initial 50			●
Miscellaneous Items	Adjust the propeller shaft alignment		● Initial 50			●
	Replace rubberized hoses (fuel and water)	Replace every 2 years or every 2000 hours, whichever comes first.				

* For EPA requirements, see *Inspection and Maintenance of EPA Emission-Related Parts for Non-Road and CI Marine Engines* on page 64.

Note: These procedures are considered normal maintenance and are performed at the owner's expense.

PERIODIC MAINTENANCE

Inspection and Maintenance of EPA Emission-Related Parts

Marine diesel engines greater than 37 kW: 6CX530 is certified as an EPA CI marine engine.

Inspection and Maintenance of EPA Emission-Related Parts for Non-Road and CI Marine Engines

Action	Interval
Clean fuel injection nozzle	1500 hours
Check fuel injection nozzle pressure and spray pattern	3000 hours
Check fuel injection pump adjustment	
Check turbocharger adjustment (if equipped)	
Check electronic engine control unit and its associated sensors and actuators (if equipped)	

Note: The inspection and maintenance items shown above are to be performed at your Yanmar Marine dealer or distributor.

PERIODIC MAINTENANCE PROCEDURES

WARNING! ALWAYS wear personal protective equipment. Refer to Exposure Hazard on page 6.

Daily Checks

Before you head out for the day, make sure the Yanmar engine is in good operating condition. **CAUTION! It is important to perform the daily checks as listed in this Operation Manual. Periodic maintenance prevents unexpected downtime, reduces the number of accidents due to poor engine performance and helps extend the life of the engine.**

Make sure you check the following items.

Visual Checks

1. Check for engine oil leaks.
2. Check for fuel leaks. **WARNING! Avoid skin contact with the high-pressure diesel fuel spray caused by a fuel system leak, such as a broken fuel injection line. High-pressure fuel can penetrate your skin and result in serious injury. If you are exposed to high-pressure fuel spray, obtain prompt medical treatment. NEVER check for a fuel leak with your hands. ALWAYS use a piece of wood or cardboard. Have your authorized Yanmar Marine dealer or distributor repair any damage.**
3. Check for engine coolant leaks.
4. Check for damaged or missing parts.
5. Check for loose, missing or damaged fasteners.
6. Check the electrical harnesses for cracks, abrasions, and damaged or corroded connectors.
7. Check hoses for cracks, abrasions, and damaged, loose or corroded clamps.

8. Check the fuel filter / water separator for presence of water and contaminants. If you find any water or contaminants, drain the fuel filter / water separator. *See Draining the Fuel / Water Separator on page 70.* If you have to drain the fuel filter / water separator frequently, drain the fuel tank and check for the presence of water in your fuel supply. *See Draining the Fuel Tank on page 66.*

CAUTION! If any problem is noted during the visual check, the necessary corrective action should be taken before operating the engine.

Checking Diesel Fuel, Engine Oil and Engine Coolant Levels

Follow the procedures in *Diesel Fuel on page 27, Engine Oil on page 36 and Engine Coolant on page 41* to check these levels.

Checking and Refilling Marine Gear Oil

Refer to the *Operation Manual* for the marine gear.

Checking the Battery Electrolyte Level

Check the battery electrolyte level before use. *See Checking the Battery Electrolyte Level (Serviceable Batteries Only) on page 71.*

Checking the Alternator Belt

Check the belt tension before use. *See Checking and Adjusting the Alternator Belt Tension on page 68.*

Checking the Alarm Indicators

When operating the start switch on the rocker switch panel, check that there is no alarm message on the display and the alarm indicators work normally. *See Electronic Control System (ECS) on page 19.*

PERIODIC MAINTENANCE

Preparing Fuel, Oil, and Coolant in Reserve

Prepare sufficient fuel for the day's operation. Always store engine oil and coolant in reserve (for at least one refill) onboard, to be ready for emergencies.

After Initial 50 Hours of Operation

Perform the following maintenance after the initial 50 hours of operation.

- **Draining the Fuel Tank**
- **Changing the Engine Oil and Replacing the Engine Oil Filter Element**
- **Changing the Marine Gear Oil and Cleaning the Marine Gear Oil Filter (if equipped)**
- **Checking and Adjusting the Alternator Belt Tension**
- **Inspecting and Adjusting the Intake / Exhaust Valve Clearance**
- **Checking and Adjusting the Electronic Control Unit Connectors**
- **Adjusting the Propeller Shaft Alignment**

Draining the Fuel Tank

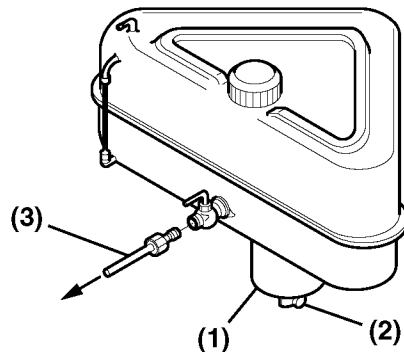

0004542

Figure 1

- 1 – Sediment Bowl**
- 2 – Drain Cock**
- 3 – Fuel Line to Engine**

Note: Fuel tank not supplied by Yanmar. Actual equipment may differ.

1. Put a pan under the drain cock (**Figure 1, (2)**) to catch fuel.

2. Open the drain cock and drain water and sediment. Close the drain cock when the fuel is clean and free of air bubbles.

Changing the Engine Oil and Replacing the Engine Oil Filter Element

The engine oil on a new engine becomes contaminated from the initial break-in of internal parts. It is very important that the initial oil replacement is performed as scheduled.

It is easiest and most effective to drain the engine oil after operation while the engine is still warm. **WARNING! If you must drain the engine oil while it is still hot, stay clear of the hot engine oil to avoid being burned. ALWAYS wear eye protection.**

1. Turn the engine off.
2. **NOTICE:** Prevent dirt and debris from contaminating engine oil. Carefully clean the oil filler cap on the cylinder block side cover plate and the surrounding area before you remove the oil filler cap. Remove the engine oil filler cap on the cylinder block side cover plate. Attach the oil drain pump (if equipped) and pump out the oil.
NOTICE: ALWAYS be environmentally responsible.

3. Turn the engine oil filters ((**Figure 2, (1)**) and (**Figure 2, (2)**)) counterclockwise with a filter wrench.

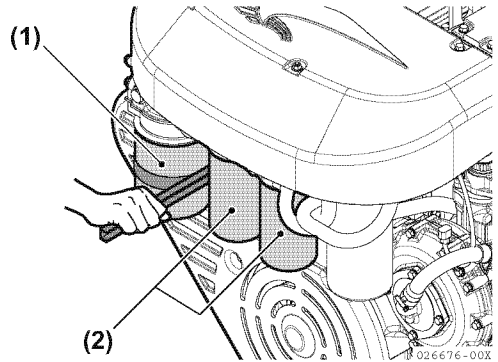

Figure 2

- 1 – Bypass Oil Filter**
- 2 – Full Flow Oil Filters**

4. Remove the engine oil filters.
5. Install new engine oil filters and tighten by hand until the seal touches the housing.
6. Turn the filters an additional 3/4 to one turn with a filter wrench.
7. Fill with new engine oil. See *Adding Engine Oil* on page 40. **NOTICE:** NEVER mix different types of engine oil. This may adversely affect the lubricating properties of the engine oil. NEVER overfill. Overfilling may result in white exhaust smoke, engine overspeed or internal damage.
8. Perform a trial run and check for oil leaks.
9. Approximately 10 minutes after stopping the engine, remove the oil dipstick and check the oil level. Add oil if the level is too low. Install and tighten the aluminum casting cover.

PERIODIC MAINTENANCE

Cleaning the Marine Gear Oil Filter (If Equipped) and Changing the Marine Gear Oil

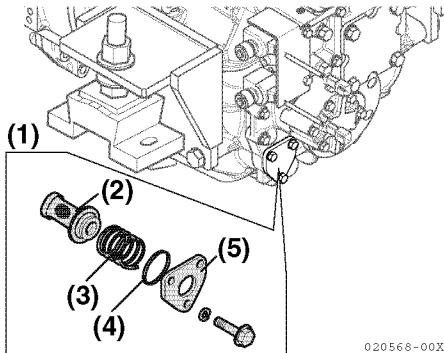

Figure 3

Note: 6CX530 engine with KMH70A marine gear shown. Refer to the marine gear *Operation Manual* for procedure.

1. Remove the cap from the filler port and attach an oil drain pump. Drain the marine gear oil. **NOTICE: ALWAYS be environmentally responsible.**
2. KMH70A Marine Gear: Wash the marine gear oil filter:
 - (a) Remove side cover (**Figure 3, (5)**) and remove the filter (**Figure 3, (2)**).
 - (b) Clean the filter thoroughly with kerosene or clean diesel fuel.
 - (c) Hold the filter in place with the coil spring (**Figure 3, (3)**) and insert into the case. Install a new O-ring (**Figure 3, (4)**) in the side cover.
 - (d) Install the side cover and tighten the side cover bolts.
3. Fill the marine gear with clean marine gear oil. See *Marine Gear Oil Specifications* on page 40.
4. Perform a trial run and check for oil leaks.
5. Approximately 10 minutes after stopping the engine, remove the oil dipstick and check the oil level. Add oil if the level is too low.

Checking and Adjusting the Alternator Belt Tension

WARNING! Perform this check with engine off and key removed to avoid contact with moving parts.

NOTICE: When there is not enough tension in the belt, it will slip and the coolant pump will fail to supply coolant. Engine overheating and seizure will result.

NOTICE: When there is too much tension in the belt, the belt will become damaged more quickly and the coolant pump bearing may be damaged.

NOTICE: NEVER get any oil on the belt(s). Oil on the belt causes slipping and stretching. Replace the belt if it is damaged.

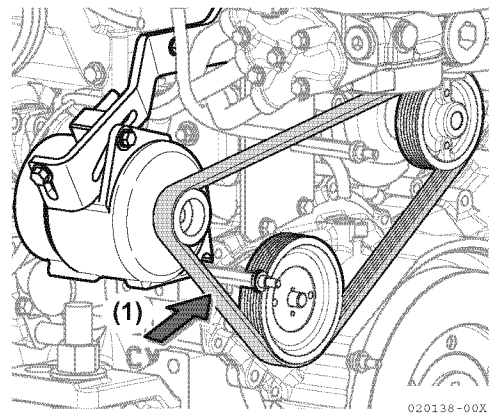

Figure 4

1. Remove the belt cover.
2. Check the belt by pushing on the middle of the belt (**Figure 4, (1)**) with your finger.

With moderate force, the belt should deflect 5 to 6 mm (approximately 1/4 in.).
3. Loosen the alternator bolt and move the alternator to adjust the belt tension.
4. Install the belt cover.

Note: If replacing the belt, loosen the pulley of the coolant pump to remove belt.

Inspecting and Adjusting Intake / Exhaust Valve Clearance

Proper adjustment is necessary to maintain the correct timing for opening and closing the valves. Improper adjustment will cause the engine to run noisily, resulting in poor engine performance and engine damage. See your authorized Yanmar Marine dealer or distributor to adjust the intake / exhaust valve clearance.

Checking and Adjusting the Electronic Control Unit Connectors

KMH70A

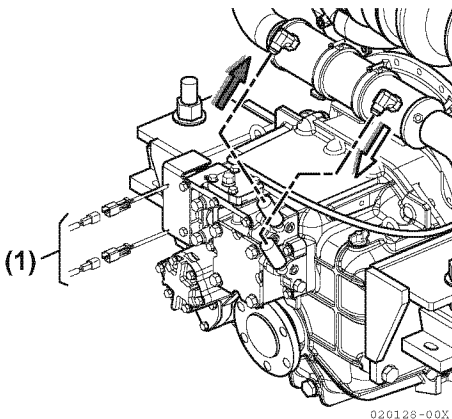

Figure 5

1 – Electronic Control Unit (ECU) Connectors

1. Ensure the ECU connectors (Figure 5, (1)) are tight.

Adjusting the Propeller Shaft Alignment

The flexible engine mounts are compressed a little during initial engine operation and may cause misalignment between the engine and the propeller shaft.

After the first 50 hours of operation, the alignment should be checked and readjusted if necessary. This is considered normal maintenance and the adjustment requires specialized knowledge and techniques. Consult your authorized Yanmar Marine dealer or distributor.

Check for any unusual noise and vibration in the engine / boat hull, while increasing and decreasing the engine speed gradually.

If there is unusual noise and / or vibration, this maintenance requires specialized knowledge and techniques. See your authorized Yanmar Marine dealer or distributor to adjust the propeller shaft alignment.

Every 50 Hours of Operation

- Draining the Fuel / Water Separator
- Checking the Battery Electrolyte Level (Serviceable Batteries Only)

Draining the Fuel / Water Separator

WARNING! When removing any fuel system component to perform maintenance (such as changing the fuel filter), put an approved container under the opening to catch the fuel. NEVER use a shop rag to catch the fuel. Vapors from the rag are flammable and explosive. Wipe up any spills immediately. Wear eye protection. The fuel system is under pressure and fuel could spray out when removing any fuel system component.

The 6CX530 engine may already have the optional fuel / water separator installed. If not, the customer should install a fuel / water separator attached to the hull.

Hull Attached Fuel / Water Separator (Example Shown)

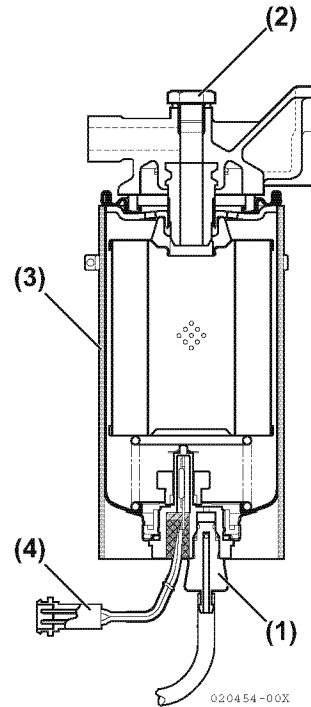

Figure 6

- 1 – Drain Plug (Water Drain)**
- 2 – Air Bleed Screw**
- 3 – Cover (Fire Protect)**
- 4 – Sensor Cable (Water Level)**

1. Close the fuel cock of the fuel tank.
2. Loosen the drain plug (**Figure 6, (1)**) of water separator and drain off any water or dirt collected inside.
3. After draining, tighten the air bleed screw (**Figure 6, (2)**).
4. Be sure to bleed air from the fuel system. See *Bleeding the Fuel System* on page 34.

Fuel / Water Separator (Not Supplied by Yanmar)

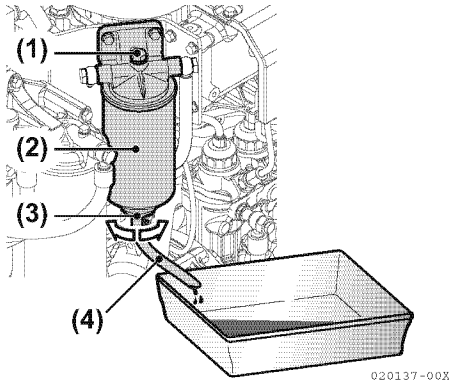

Figure 7

Note: If no water or fuel drains from the fuel / water separator (**Figure 7, (2)**), loosen the air bleed screw (**Figure 7, (1)**) on the fuel filter 2 to 3 times. This can occur when the fuel level is lower than the position of the fuel / water separator.

1. Make sure the fuel cock of the fuel tank is closed. Remove the aluminum casting cover of engine front end.
2. Loosen the hose clamp and remove the fire-resistant cover, which is installed to the lower part of the fuel / water separator to protect the water alarm switch.
3. Attach a tube (**Figure 7, (4)**) to the drain plug (**Figure 7, (3)**).
4. Loosen the drain plug at the bottom of the fuel / water separator counterclockwise and drain off any water or sediment.

Note: If there is a large quantity of water and sediment in the fuel / water separator, also drain the fuel tank. *See Draining the Fuel Tank on page 66.*

5. Tighten the drain plug.
6. Remove the drain tube.

7. Install the fire-resistant cover and tighten the hose clamp.
8. Bleed air from the fuel system.
9. Install and tighten the aluminum casting cover. *See Bleeding the Fuel System on page 34.*

Checking the Battery Electrolyte Level (Serviceable Batteries Only)

WARNING! Batteries contain sulfuric acid. NEVER allow battery fluid to come in contact with clothing, skin or eyes. Severe burns could result. ALWAYS wear safety goggles and protective clothing when servicing the battery. If battery fluid contacts the eyes and / or skin, immediately flush the affected area with a large amount of clean water and obtain prompt medical treatment.

NOTICE: NEVER turn off the battery switch (if equipped) or short the battery cables during operation. Damage to the electric system will result.

NOTICE: NEVER operate with insufficient battery electrolyte. Operating with insufficient electrolyte will destroy the battery.

NOTICE: Battery fluid tends to evaporate in high temperatures, especially in summer. In such conditions, inspect the battery earlier than specified.

1. Turn the battery master switch to OFF (if equipped) or disconnect the negative (-) battery cable.
2. Do not operate with insufficient battery electrolyte as the battery will be destroyed.
3. Remove the plugs and check the electrolyte level in all cells. *NOTICE: NEVER attempt to remove the covers or fill a maintenance-free battery.*

PERIODIC MAINTENANCE

4. If the level is lower than the minimum, fill level (**Figure 8, (1)**), fill with distilled water (**Figure 8, (2)**) (available in the grocery store) up to the upper limit (**Figure 8, (3)**) of the battery.

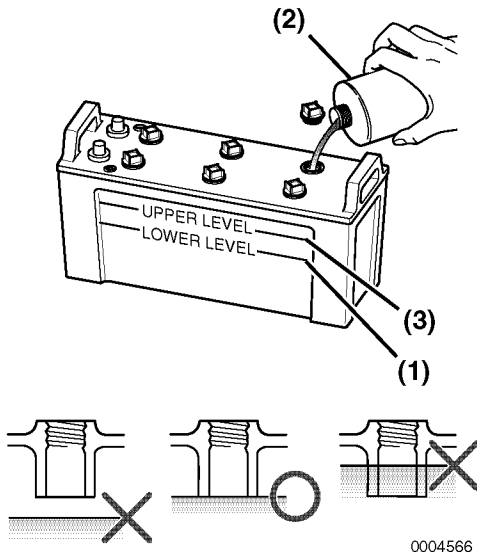

Figure 8

Note: The maximum fill level is approximately 10 to 15 mm (3/8 to 9/16 in.) above the plates.

Every 250 Hours of Operation

Perform the following maintenance every 250 hours or one year of operation, whichever comes first.

- Draining the Fuel Tank
- Replacing the Fuel Filter Element
- Changing the Engine Oil and Replacing the Engine Oil Filter Element
- Changing the Marine Gear Oil and Cleaning Marine Gear Oil Filter Element (If Equipped)
- Checking or Replacing the Seawater Impeller
- Replacing the Zinc Anode
- Changing the Coolant
- Cleaning the Intake Silencer (Air Cleaner) Element
- Cleaning the Turbocharger
- Cleaning the Exhaust / Seawater Mixing Elbow
- Adjusting the Alternator Belt Tension
- Checking the Wiring Connectors
- Tightening All Major Nuts and Bolts

Draining the Fuel Tank

See *Draining the Fuel Tank* on page 66.

Replacing the Fuel Filter Element

WARNING! *When removing any fuel system component to perform maintenance (such as replacing the fuel filter), put an approved container under the opening to catch the fuel. NEVER use a shop rag to catch the fuel. Vapors from the rag are flammable and explosive. Wipe up any spills immediately. Wear eye protection. The fuel system is under pressure and fuel could spray out when removing any fuel system component.*

WARNING! *Perform this check with engine off and key removed to avoid contact with moving parts.*

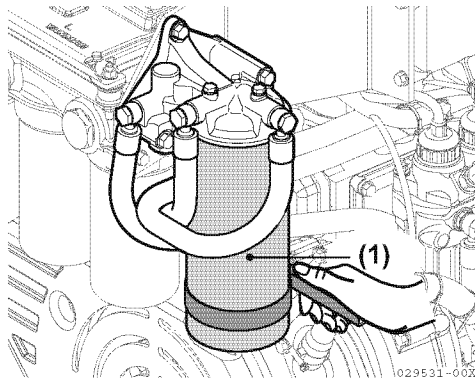

Figure 9

1. Close the fuel cock of the fuel tank. Remove the aluminum casting cover of engine front end.
2. Remove the fuel filter element (**Figure 9, (1)**) with a filter wrench.

Note: When removing the fuel filter, hold the bottom of the fuel filter with a cloth to prevent the fuel from spilling. Wipe up any spilled fuel immediately.

3. Apply a thin film of clean diesel fuel to the sealing surface of the new filter gasket.

Component	Part No.
Fuel Filter Cartridge	127677-55130

4. Install a new fuel filter and tighten hand-tight. Use a filter wrench and tighten to 3/4 or 1 turn.
5. Bleed the fuel system. See *Bleeding the Fuel System* on page 34. Dispose of waste properly.
6. Install and tighten the aluminum casting cover. See *Bleeding the Fuel System* on page 34. Dispose of waste properly. Check for fuel leaks. **WARNING! Avoid skin contact with the high-pressure diesel fuel spray caused by a fuel system leak, such as a broken fuel injection line. High-pressure fuel can penetrate your skin and result in serious injury. If you are exposed to high-pressure fuel spray, obtain prompt medical treatment. NEVER check for a fuel leak with your hands. ALWAYS use a piece of wood or cardboard. Have your authorized Yanmar Marine dealer or distributor repair any damage.**

PERIODIC MAINTENANCE

Changing the Engine Oil and Replacing the Engine Oil Filter Element

See *Changing the Engine Oil and Replacing the Engine Oil Filter Element* on page 67.

Changing the Marine Gear Oil and Cleaning the Marine Gear Oil Filter Element (If Equipped)

See *Cleaning the Marine Gear Oil Filter (If Equipped)* and *Changing the Marine Gear Oil* on page 68.

Checking and Replacing the Seawater Pump Impeller

1. Loosen the side cover bolts and remove the side cover.
2. Inspect the inside of the seawater pump with a flashlight. If any of the following are found, disassembly and maintenance are required:
 - Impeller blades are cracked or nicked. Edges or surfaces of the blades are marred or scratched.
 - Wear plate is damaged.
3. If no damage is found when inspecting the inside of the pump, install the O-ring and side cover.
4. If a large amount of water leaks continuously from the water drain line below the seawater pump during operation, replace the mechanical seal. See your authorized Yanmar Marine dealer or distributor.

Replacing the Seawater Pump Impeller

Note: The impeller must be replaced periodically (every 1000 hours) even if there is no damage.

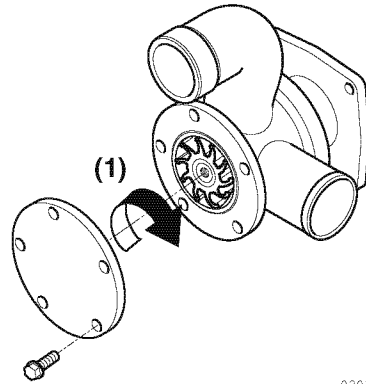

Figure 10

1 – Rotation Direction

There are two types of special service tools for removing the impeller:

NOTICE: The seawater pump turns counterclockwise as viewed from the side cover, so the impeller must be installed as shown **Figure 10**. If the impeller has been removed it must be installed in the correct direction. Additionally, if the engine is being turned over manually, be careful to turn it in the correct direction. Incorrect turning will twist the impeller blades and cause damage.

Puller A (Standard)
Part No. 129671-92110

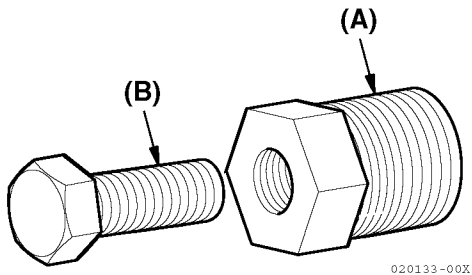

Figure 11

Puller A	Jack Screw B
M18x1.5	M10x40

1. Remove the side cover of the seawater pump.
2. Install the puller (**Figure 11, (A)**) in the impeller.

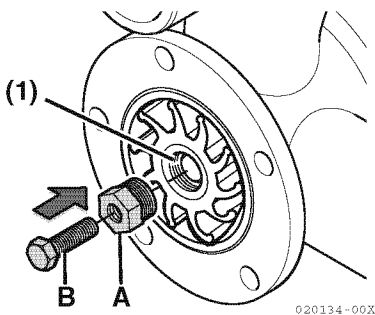

Figure 12

3. Turn the jack screw (**Figure 11, (B)**) clockwise to remove the impeller from the pump body.

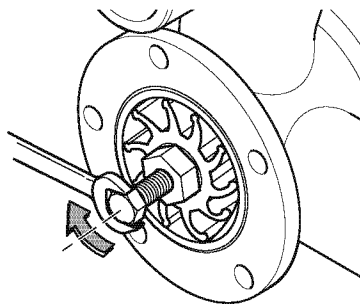

Figure 13

Note: When replacing a used impeller with a new one, the impeller must have an M18x1.5 thread (**Figure 12, (1)**). Turn the M18 screw-side of the impeller to the cover side and install (**Figure 13**).

Puller B (Option) Part No. 129671-92100

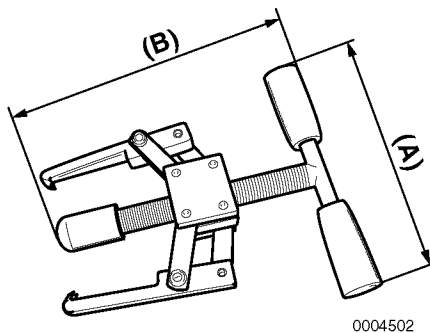

Figure 14

A	B
110 mm (4.33in.)	140 mm (5.51 in.)

PERIODIC MAINTENANCE

Clean the Seawater Passages (Inlet Side Cover of Oil Cooler)

1. Loosen the bolts of seawater pipe between seawater pump and oil cooler side cover and slide the seawater pipe to the pump side.
2. Loosen inlet side cover bolts of oil cooler and remove the inlet side cover.
3. Remove trash and seaweed around inlet of tube stack.

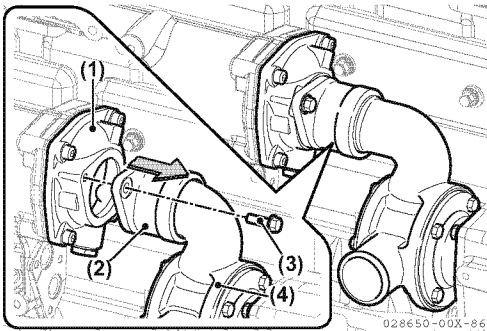

Figure 15

- 1 – Oil Cooler Side Cover
- 2 – Seawater Pipe
- 3 – Bolt
- 4 – Seawater Pump

Replacing the Zinc Anode

The timing for replacing zinc anode varies depending on the characteristics of the seawater and operational conditions. Inspect the zinc periodically and remove the corroded area on the surface. Replace the zinc anode when it has decreased to less than 1/2 of the original volume. If replacement of zinc is neglected and operation is continued with a small volume of zinc anode, corrosion of the seawater cooling system will occur and water leakage or parts breakage will result. The label shown in the figure is stamped on the plugs which have the zinc anode. Be sure to close the seacock before removing the plug to replace the zinc anode.

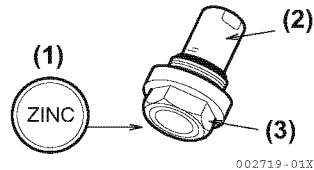

Figure 16

- 1 – Sticker
- 2 – Zinc Anode
- 3 – Plug

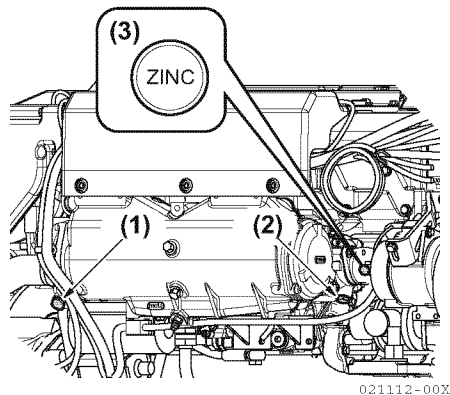

Figure 17

- 1 – Heat Exchanger Zinc Anode
- 2 – Oil Cooler Zinc Anode
- 3 – Oil Cooler Sticker for Zinc Anode

Changing the Coolant

CAUTION! *Wear eye protection and rubber gloves when you handle engine coolant. If contact with the eyes or skin should occur, flush eyes and wash immediately with clean water.*

Replace coolant every year.

NOTICE: NEVER mix different types and / or colors of coolants.

Discard old coolant in an approved manner according to environmental laws.

Note: If LLC is used, replace coolant every 2 years.

Note: The drain cocks are opened before shipping from the factory.

1. Open all coolant drain cocks.
2. Allow the coolant to drain completely. Dispose of waste properly.
3. Close all the drain cocks.
4. Fill coolant tank and coolant recovery tank with appropriate coolant. See *Engine Coolant Specifications on page 41* and See *Checking and Adding Coolant on page 42*.

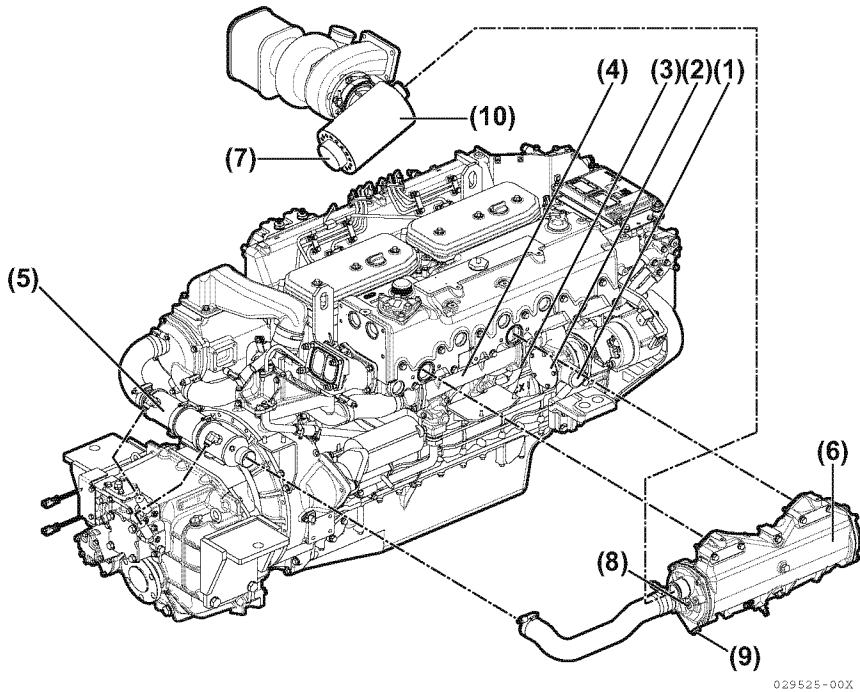
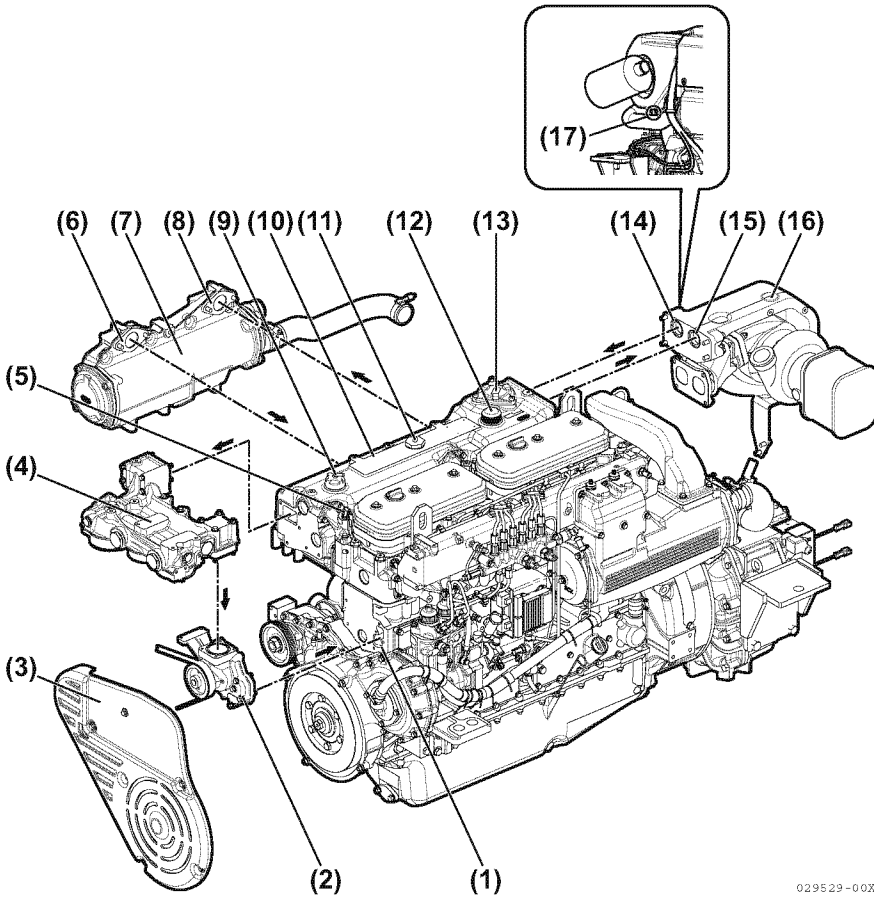

Figure 18

- | | |
|--|--|
| 1 – Seawater Inlet | 6 – Heat Exchanger (Engine Coolant) |
| 2 – Seawater Pump | 7 – Exit Exhaust Gas and Seawater Mixing |
| 3 – Zinc Anode and Seawater Drain Plug (Engine Oil Cooler) | 8 – To Stern Bearing Cooling Seawater |
| 4 – Engine Oil Cooler | 9 – Zinc Anode (Heat Exchanger) |
| 5 – Marine Gear Oil Cooler | 10 – Mixing Elbow (Not Supplied by Yanmar) |



029529-00X

Figure 19

- | | |
|---|---|
| 1 – Coolant Inlet (Cylinder Block) | 9 – Filler Cap (Coolant) |
| 2 – Coolant Pump (Fresh Water) | 10 – Coolant Tank (Inside Exhaust Manifold) |
| 3 – Belt Cover | 11 – Coolant Level Sensor |
| 4 – Coolant Path (Oil Filter Mount) | 12 – Axially Coolant Filler Port |
| 5 – Sensor (Coolant Temperature at Heat Exit) | 13 – Thermostat Cover |
| 6 – Coolant Outlet (to Exhaust Manifold) | 14 – Coolant Outlet (from TC Cover) |
| 7 – Heat Exchanger (Fresh Water Cooling) | 15 – Water Cooled Turbocharger Cover |
| 8 – Coolant Inlet (from Exhaust Manifold) | 16 – Coolant Inlet (to TC Cover) |
| | 17 – Coolant Drain Cock |

Cleaning the Intake Silencer (Air Cleaner) Element

1. Disassemble the intake silencer (air cleaner).
2. Remove the element. Clean the element and housing with a neutral detergent.
3. Dry completely and reassemble.

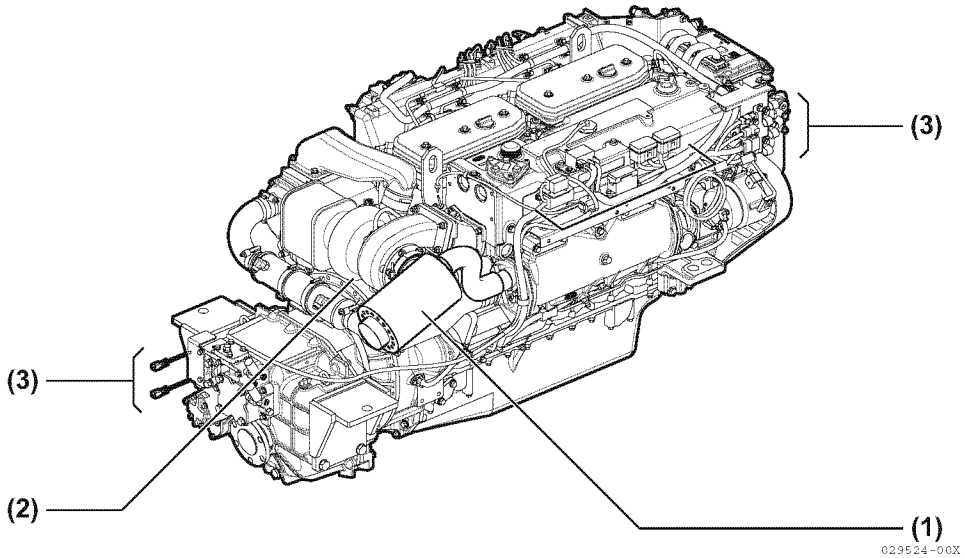

Figure 20

- 1 – Exhaust / Seawater Mixing Elbow (Not Supplied by Yanmar)**
2 – Turbocharger

- 3 – Wiring Cable Connectors**

Cleaning the Exhaust / Seawater Mixing Elbow

The mixing elbow (**Figure 19, (1)**) is attached to the turbocharger (**Figure 19, (2)**). The exhaust gas is mixed with seawater in the mixing elbow.

1. Remove the mixing elbow.
2. Clean any dirt and scale out of the exhaust and seawater passages.
3. If the mixing elbow is damaged, repair or replace.
4. Inspect the gasket and replace if necessary.

Cleaning the Turbocharger

Contamination of the turbocharger causes revolutions to drop and engine output to fall.

If a significant drop in engine output is noted (10% or more), clean the turbocharger.

This should be done only by a trained and qualified technician. See your authorized Yanmar Marine dealer or distributor.

Adjusting the Alternator Belt Tension

See Checking and Adjusting the Alternator Belt Tension on page 68.

Checking the Wiring Connectors

Have your authorized Yanmar Marine dealer or distributor check the wiring connectors (**Figure 19, (3)**).

Tightening All Major Nuts and Bolts

See Tightening Fasteners on page 59 or see your authorized Yanmar Marine dealer or distributor.

Every 500 Hours of Operation

Perform the following maintenance every 500 hours or 2 years of operation, whichever comes first.

- **Replacing the Rubber Hoses**

Replacing the Rubber Hoses

Replace the rubber hoses every 2000 hours or 2 years, whichever comes first.

See your authorized Yanmar Marine dealer or distributor.

Every 1000 Hours of Operation

Perform the following maintenance every 1000 hours or 4 years of operation, whichever comes first.

- **Checking the Fuel Injection Timing**
- **Checking the Fuel Injector Spray Pattern**
- **Replacing the Seawater Pump Impeller**
- **Replacing the Exhaust / Water Mixing Elbow**
- **Cleaning and Checking the Seawater Passages**
- **Replacing the Alternator Belt**
- **Adjusting the Intake / Exhaust Valve Clearance**
- **Checking the Remote Control Cable Operation**
- **Adjusting the Propeller Shaft Alignment**

Checking the Fuel Injection Timing

See your authorized Yanmar Marine dealer or distributor.

Checking the Fuel Injector Spray Pattern

See your authorized Yanmar Marine dealer or distributor.

Replacing the Seawater Pump Impeller

The seawater impeller must be replaced every 1000 hours even if it is not damaged.

See Checking and Replacing the Seawater Pump Impeller on page 74.

Replacing the Exhaust / Water Mixing Elbow

Replace the mixing elbow with a new one every 1000 hours or 2 years, whichever comes first, even if no damage is found.

Cleaning and Checking the Seawater Passages

After prolonged use, clean the seawater passages to remove trash, scale, rust and other contaminants that collect in the cooling water passages. This can cause declining cooling performance. The following items need to be inspected:

- Heat Exchanger
- Pressure Cap

See your authorized Yanmar Marine dealer or distributor.

Replacing the Alternator Belt

See Checking and Adjusting the Alternator Belt Tension on page 68.

Adjusting the Intake / Exhaust Valve Clearance

See your authorized Yanmar Marine dealer or distributor.

Checking the Remote Control Cable Operation

See your authorized Yanmar Marine dealer or distributor.

Adjusting the Propeller Shaft Alignment

See your authorized Yanmar Marine dealer or distributor.

LONG-TERM STORAGE

If the engine will not be used for an extended period of time, special measures should be taken to protect the cooling system, fuel system and combustion chamber from corrosion and the exterior from rusting.

The engine can normally stand idle for up to 6 months. If it remains unused for longer than this, please contact your authorized Yanmar Marine dealer or distributor.

Before performing any storage procedures within this section, review the *Safety* section on page 3.

In cold temperatures or before long-term storage, be sure to drain the seawater from the cooling system.

WARNING! NEVER remove the coolant filler cap if the engine is hot. Steam and hot engine coolant will spray out and seriously burn you. Allow the engine to cool down before you attempt to remove the cap.

CAUTION! DO NOT drain the coolant system. A full coolant system will prevent corrosion and frost damage.

CAUTION! If seawater is left inside of the engine, it may freeze and damage parts of the cooling system when the ambient temperature is below 0°C (32°F).

PREPARING THE ENGINE FOR LONG-TERM STORAGE

CAUTION! Do not drain closed cooling system for long-term storage. Antifreeze must be used to avoid freezing and damaging of components. Antifreeze will prevent rusting during long-term storage.

Note: If the engine is close to a periodic maintenance interval, perform those maintenance procedures before putting the engine into long-term storage.

1. Wipe off any dust or oil from the outside of engine.
2. Drain the water from fuel filters.
3. Drain the fuel tank completely or fill the tank to prevent condensation.
4. Seal the intake silencer, exhaust pipe, etc. to prevent moisture or contamination from entering engine.
5. Completely drain the bilge in hull bottom.
6. Waterproof the engine room to prevent rain or seawater from entering.
7. Charge the battery once a month to compensate for battery's self-discharge.
8. Remove the key from the key switch and cover the key switch with moisture cap.

DRAINING THE SEAWATER COOLING SYSTEM

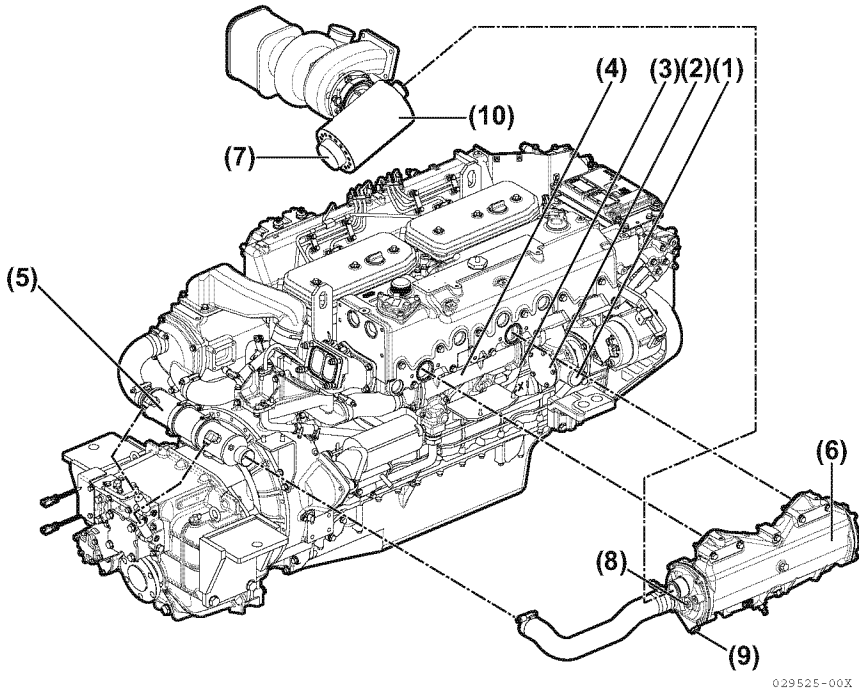

Figure 1

- 1 – Seawater Inlet
- 2 – Seawater Pump
- 3 – Zinc Anode and Seawater Drain Plug (Engine Oil Cooler)
- 4 – Engine Oil Cooler
- 5 – Marine Gear Oil Cooler

- 6 – Heat Exchanger (Engine Coolant)
- 7 – Exit Exhaust Gas and Seawater Mixing
- 8 – To Stern Bearing Cooling Seawater
- 9 – Zinc Anode (Heat Exchanger)
- 10 – Mixing Elbow (Not Supplied by Yanmar)

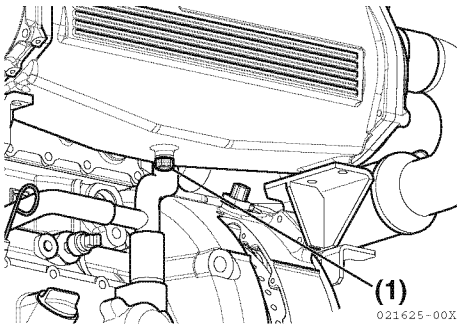

Figure 2

1 – Condensed Water Drain Plug

In cold temperatures or before long term storage, be sure to drain the seawater from the seawater cooling system.

NOTICE: Drain the seawater from the seawater cooling system after the engine has cooled down. Be careful to avoid burns.

NOTICE: If seawater is left inside, it may freeze and damage parts of the cooling system (heat exchanger, seawater pump, etc.) when ambient temperature is below 32°F (0°C).

1. Loosen the seawater drain plug and drain off the seawater inside the engine. If no liquid comes from the drain plug, it may be necessary to use a stiff wire to remove any debris to allow drainage.
2. Loosen the 6 bolts attaching the side cover of the seawater pump, remove the cover and drain the water from inside. Retighten the bolts when finished.
3. Close the drain plug.

Do not drain the fresh water / coolant in the cold season or before long-term storage. If LLC (Long Life Coolant) has not been added to the cooling fresh water, be sure to add LLC or drain off the fresh water from the cooling system daily after use.

NOTICE: If the fresh water without LLC is not removed, it may freeze and damage parts of the cooling water system (heat exchanger, cylinder block, cylinder head, etc.) when ambient temperature is below 0°C (32°F).

When draining the fresh water:

- Open the freshwater drain cocks (2 positions) and drain the fresh water from inside the engine.
- Close the drain cocks after draining the fresh water.

Carry out the following periodic inspection before placing the engine in storage:

1. Clean the outside of the engine wiping off any dust or oil.
2. To prevent condensation inside the fuel tank, either drain off the fuel or fill the tank.
3. Cover the turbocharger, exhaust pipe, etc. with vinyl sheets and seal them to prevent moisture from entering.
4. Drain bilge in the hull bottom completely. Water may leak into the boat when it is moored, and whenever possible it should be hauled out, covered and blocked.
5. Waterproof the engine room to prevent rain and seawater from entering.

LONG-TERM STORAGE

During long-term storage, charge the battery once a month to compensate for the battery's self-discharge.

When storing an engine for a long time, run the engine periodically according to the following procedure to prevent rust inside the engine:

- Change the engine oil and the filters before running the engine.
- Supply fuel if the fuel in the fuel tank was removed, and bleed the fuel system of air.
- Confirm that there is the coolant in the engine.
- Operate the engine at the low idling speed for about 5 minutes (if possible, once a month).

TROUBLESHOOTING

Before performing any troubleshooting procedures within this section, review the *Safety* section on page 3.

If a problem occurs, stop the engine immediately. Refer to the Symptom column in the Troubleshooting Chart to identify the problem.

TROUBLESHOOTING AFTER STARTING

Just after the engine has started, check the following items at a low engine speed:

Is sufficient water being discharged from the seawater outlet pipe?

If the discharge is low, stop the engine immediately. Identify the cause and repair.

Is the exhaust color normal?

The continuous emission of black exhaust smoke indicates engine overloading. This shortens the engine's life and should be avoided.

Are there abnormal vibrations or noise?

Depending on the hull structure, engine and hull resonance may suddenly increase at certain engine speed ranges, causing heavy vibrations. Avoid operation in this speed range. If any abnormal sounds are heard, stop the engine and inspect for cause.

Alarm sounds during operation.

If the alarm sounds during operation, lower the engine speed immediately, check the warning lamps and stop the engine for repairs.

Is there water, oil or fuel leakage? Are there any loose bolts or connections?

Check the engine room daily for any leaks or loose connections.

Is there sufficient fuel in the fuel tank?

Refill fuel in advance to avoid running out of fuel. If the tank runs out of fuel, bleed the fuel system. See *Bleeding the Fuel System on page 34*.

When operating the engine at low speed for long periods of time, race the engine once every 2 hours. Racing the engine with the clutch in NEUTRAL, accelerate from the low speed position to the high speed position and repeat this process about five times. This is done to clean out carbon from the cylinders and the fuel injection valves.

NOTICE: Neglecting to race the engine will result in poor exhaust color and reduce engine performance.

Periodically operate the engine near maximum speed while underway. This will generate higher exhaust temperatures, which will help clean out hard carbon deposits, maintain engine performance and prolong the life of the engine.

TROUBLESHOOTING INFORMATION

If the engine does not operate properly, refer to the *Troubleshooting Chart on page 89* or see your authorized Yanmar Marine dealer or distributor.

Supply the authorized Yanmar Marine dealer or distributor with the following information:

- Model name and serial number of your engine
- Boat model, hull material, size (tons)
- Use, type of boating, number of hours run
- Total number of operation hours (refer to hourmeter), age of boat
- The operating conditions when the problem occurs:
 - Engine rpm
 - Color of exhaust smoke
 - Type of diesel fuel
 - Type of engine oil
 - Any abnormal noises or vibration
 - Operating environment such as high altitude or extreme ambient temperatures, etc.
 - Engine maintenance history and previous problems
 - Other factors that contribute to the problem

TROUBLESHOOTING CHART

Symptom	Probable Cause	Measure
Indicators light on the instrument panel and alarm sounds during operation	Shift to low speed operation immediately, and check which indicator has come on. Stop the engine and inspect. If no abnormality is identified and there is no problem with operation, return to port at lowest speed and request repairs.	
Engine does not start or starts with difficulty:		
Pinion gear does not engage	Loose terminal of battery / engage magnet	Tighten.
	Poor contact of starting switch	Correct with sandpaper or replace.
	Open coil of magnet switch	Replace.
	Burr at gear tooth tip	Correct.
	Poor clearance between pinion and ring gear	Correct.
Pinion gear is engaged with ring gear, but does not rotate	Loose battery / starter terminal	Tighten.
	Poor contact of engage magnet switch	Correct with sandpaper.
	Worn brush	Replace.
	Open circuit of starter coil	Replace.
	Slippage of starter / clutch	Replace.
	Excessive resistance of cable between battery and starter	Increase the cable size or shorten.
	Insufficient battery charge	Charge.
No fuel injection	Incomplete priming of fuel system	Carry out sufficient priming.
	Clogged fuel inlet filter	Replace.
	Fuel level in fuel tank is low	Add fuel.
	Closed cock of fuel tank	Open cock.
	Clogged fuel pipe	Clean.
	Failure of fuel feed pump	Overhaul or replace.
Failure of fuel injection valve	Faulty valve seat	Replace.
	Sticking of nozzle	Replace.
	Worn nozzle	Replace.
	Clogged injection hole	Replace.
	Drop in injection pressure	Replace.
Failure of fuel injection pump	Air trapped in pump	Bleed air from pump.
Failure in fuel injection system	Loose fuel injection pipe joint	Tighten.
	Broken fuel injection pipe	Replace.
	Air trapped in fuel injection pipe	Bleed air from pipe.

TROUBLESHOOTING

Symptom	Probable Cause	Measure
Engine compressed air leak	Air leak from exhaust valve	Carry out fitting of valve and seat.
	No valve clearance	Re-adjust.
	Faulty gasket / packing	Replace.
	Worn upper portion of cylinder liner	Replace.
	Worn piston ring	Replace.
	Sticking piston ring	Overhaul or replace.
	Broken valve spring	Replace.
Other	Failure of engine starting system	Inspect and conduct servicing.
	Clogged intake or exhaust pipe	Clean.
Engine is not running smoothly:		
Operation failure of injection valve	Nozzle operation failure	Replace.
	Broken valve spring	Replace.
Uneven fuel injection quantities	Clogged fuel filter	Replace.
	Faulty operation of regulator valve	Replace.
	Air trapped in fuel injection system	Bleed air from system and prime system.
	Faulty operation of fuel feed pump	Repair.
Other	Overload operation	Reduce load.
	Moving parts seized	Disassemble, inspect and conduct servicing.
	Slippage of gear box	Inspect and repair.
Engine stops suddenly:		
No fuel feed	Fuel level in fuel tank is low	Add fuel and prime.
	Air trapped in fuel system or fuel injection	Bleed air.
	Water trapped in fuel tank	Drain water from drain cock and fuel pipe, conduct priming.
	Fuel cock closed	Inspect and repair as necessary.
	Clogged fuel filter	Replace.
	Broken fuel pipe	Replace.
	Failure of fuel feed pump	Replace.
Other	Moving parts seized	Disassemble and repair, or replace.
	Overheating caused by insufficient seawater	Overhaul seawater pump and check for clogged seawater path.

Symptom	Probable Cause	Measure
Abnormal exhaust color:		
Fuel injection valve failure	Clogged injection nozzle	Replace.
	Sticking needle valve	Replace.
	Reduction in injection pressure	Replace.
	Poor atomization	Replace.
	Carbon deposit	Clean.
Turbocharger failure	Clogged filter	Clean.
	Dirty compressor side	Clean.
	Clogged turbine side	Clean.
	Damaged bearing	Replace.
Other	Overload operation	Reduce load.
	Lubricant level too high	Lower the oil level.
	Accumulated carbon deposit at intake / exhaust valve	Clean.
	Dirty air cooler	Clean.
	Poor fuel quality	Replace fuel.
	Clogged intake / exhaust valve	Clean.
Insufficient output:		
Insufficient fuel injection	Oil leak from fuel injection pipe joint	Tighten.
	Faulty operation of regulator valve	Replace.
	Clogged fuel filter	Replace.
	Clogged fuel pipe	Clean.
	Faulty fuel feed pump	Repair.
Insufficient injection by fuel injection nozzle	Clogged injection hole	Replace.
	Faulty valve seat	Replace.
	Sticking nozzle	Replace.
	Loose fuel injection pipe joint	Tighten.
	Worn nozzle	Replace.
Compressed gas leak in the engine cylinder	Gas leak from intake / exhaust valve	Conduct fitting of the valve.
	Valve clearance too small	Re-adjust.
	Worn upper portion of cylinder bore	Lap or replace.
	Worn piston ring	Replace.
	Sticking piston ring	Overhaul or replace.
Turbocharger failure	Clogged air filter	Clean.
	Dirty compressor side	Clean.
	Clogged turbine nozzle	Clean.
	Damaged bearing	Replace.

TROUBLESHOOTING

Symptom	Probable Cause	Measure
Other	Improper fuel	Replace with correct fuel.
	Clogged exhaust duct	Clean.
	Seized or overheated moving parts	Disassemble and conduct servicing.
	Insufficient seawater	Inspect seawater pump.
	Insufficient feed of engine oil	Disassemble and clean engine oil pump and filter.
Output for each cylinder is not uniform:		
Uneven fuel injection quantities	Air trapped in fuel injection pump	Bleed.
	Faulty operation of regulator valve	Overhaul or replace.
Failure of fuel injection nozzle	Oil leak from fuel injection system	Inspect and repair.
	Broken valve spring	Replace.
	Uneven injection pressures of injection valves	Replace.
	Clogged injection valve	Clean.
Knocking:		
Fuel injection nozzle failure	Reduction in injection pressure	Adjust for higher injection pressure.
	Broken fuel valve spring	Replace.
	Sticking nozzle	Disassemble and lap.
	Poor spray pattern	Overhaul.
Fuel regulator valve failure	Faulty operation of regulator valve	Repair.
Excessive quantity of fuel is injected	Excessive delivery from fuel injection pump	Replace fuel injection pump.
Other	Insufficient seawater	Replace seawater pump impeller.
	Piston clearance excessive	Replace.
	Bearing clearance excessive	Replace.
	Improper fuel	Replace with correct fuel.
	Water trapped in fuel	Replace fuel.
	Poor compression	Inspect and service.

Symptom	Probable Cause	Measure	
Breakdown of turbocharger:			
Drop in intake pressure	Dirty air filter	Clean.	
	Leak from intake piping	Repair.	
	Leak of exhaust gas	Repair.	
	High intake air temperature		Complete thermal insulation of exhaust pipe.
			Ensure intake air path is unrestricted from outside air.
			Clean air cleaner.
	Drop in air pressure in engine room	Ensure intake air path is unrestricted from outside air.	
	Broken seal ring	Replace.	
	Broken turbine impeller	Replace.	
	Broken nozzle ring	Replace.	
	Dirty turbine impeller	Clean.	
	Clogged nozzle	Clean.	
	Clogged exhaust pipe	Clean.	
Incorrect reading of pressure gauge	Replace.		
Increased intake pressure	Exhaust gas leak	Re-mount turbocharger.	
	Failure in fuel injection system	Overhaul injection pump, repair or replace any defective parts.	
		Disassemble and inspect injection valve, replace injection valve.	
	Deformed turbine nozzle	Replace.	
	Dirty turbine side	Clean.	
	Increase in load (overloading)	Reduce load.	
Incorrect reading of pressure gage	Replace.		
Abnormal vibration	Broken turbine impeller	Replace.	
	Broken compressor impeller	Replace.	
	Deposit of carbon or oxides on turbine	Remove and repair or replace.	
	Broken bearing	Replace.	
	Bent turbine shaft	Replace.	
	Loose parts or fasteners	Tighten.	
Noise	Damaged bearing	Replace.	
	Contact by revolving parts	Repair or replace.	
	Dirty or carbon deposit on turbine and compressor	Clean.	
	Entrapment of foreign matter (at turbine entrance)	Repair or replace.	
	Rapid change in load (surging)	Stabilize the load or replace turbine nozzle.	

TROUBLESHOOTING

Symptom	Probable Cause	Measure
Quick contamination of engine oil	Gas trapped in bearing housing	Repair.
	Clogged seal air path	Clean.
	Damaged seal ring	Replace.
	Clogged pressure balance path	Clean.
Pulsation of intake air pressure	Uneven cylinder combustion	Adjust for uniform combustion.
	Rapid change in load	Operate correctly.
	Excessively dirty compressor side	Clean.
	Intake temperature too high	Clean cooling fin.
Complete thermal insulation of exhaust pipe.		
Ensure intake air path is unrestricted from outside air.		
Other	Bearing seizure	Replace.
	Corrosion in compressor / turbine impeller or bearing housing	Increase the coolant temperature.
Other malfunctions:		
Noise generation	Loose flywheel set bolts	Tighten bolts.
	Loose connecting rod bolts	Tighten bolts.
	Worn crank pin	Replace.
	Excessive gear backlash	Inspect the gear; replace worn gear, shaft, and / or bushing with new ones.
Low lubrication oil pressure	Clogged engine oil filter	Replace.
	Engine oil temperature too high	Check the seawater level.
	Failure of oil pump	Overhaul or replace.
	Faulty operation of oil pump relief valve	Tighten the adjusting valve.
		Replace the safety valve.
	Low viscosity of engine oil used	Replace the engine oil.
	Insufficient engine oil quantity	Add oil.
Faulty pressure gauge or sender unit	Replace.	
Engine oil temperature too high	Insufficient seawater flow rate	Replace seawater pump impeller.
	Overloaded operation	Decrease the load.
Coolant temperature too high	Insufficient seawater	Replace seawater pump impeller.
	Faulty thermostat	Replace.
	Loose drive belt of coolant pump	Adjust the belt tension.
	Overloaded operation	Decrease the load.

FAILSAFE DIAGNOSIS FUNCTIONAL SPECIFICATION CHART

Part	Factor (DTC Description)	DTC	Failsafe action			
			Max speed derate	Max torque derate	ENG Stop	Others
Common rail pressure sensor 1 and 2	Signal too high	P0190 (Sensor 1) P1190 (Sensor 2)	(X) Only when both sensors have failure.	(X) Only when both sensors have failure.		When one sensor is broken: Switch to another sensor and continue normal behavior driving. When both sensors are broken: Limit the maximum speed. Limit the highest torque. Sensor default value = target rail pressure. Continue the operation.
	Signal too low					
	Keeping the middle range					
CR pressure	CR pressure exceeds caution value	P0088	X			
	CR pressure exceeds warning value	P0088			X	
Boost pressure	Boost pressure sensor signal too high	P0235	X			Adjust sensor default values and continue operation.
	Boost pressure sensor signal too low	P0235	X			
	Boost pressure exceeds normal range	P0234		X		
Coolant temperature	Signal too high	P0115				Warning indication. Adjust sensor default values and continue operation.
	Signal too low	P0115				
	Coolant temperature exceeds upper limit	P0217	X			
Fuel temperature sensor	Signal too high	P0180				Warning indication. Adjust sensor default values and continue operation.
	Signal too high	P0180				
	Fuel temperature exceeds upper limit	P0168				Warning indication only.

TROUBLESHOOTING

Part	Factor (DTC Description)	DTC	Failsafe action			
			Max speed derate	Max torque derate	ENG Stop	Others
Fuel temperature sensor 2	Signal too high	P0185				Warning indication. Adjust sensor default values and continue operation.
	Signal too low	P0185				
	Fuel temperature exceeds upper limit	P1168		X		
Engine oil press.	Signal too high	P0520				Warning indication. Adjust sensor default values and continue operation.
	Signal too low	P0520				
	Engine oil press. exceeds lower limit	P0524	X			
Accel sensor	Sensor signal too high	P0120				When the analog throttle is used, change it to the backup throttle. Engine speed is down to switch to backup throttle sensor.
	Sensor signal too low	P0120				
	Teleflex throttle system abnormality	P0120				
Backup acceleration sensor	Sensor signal too high	P0220				When a main accelerator is effective, activate a warning indication only.
	Sensor signal too low					
Accelerator sensors and backup accelerator sensors	Both sensors blow out	U0140		X		Keep low torque speed.
ECU temperature	Sensor signal too high	P0666				Warning indication. Adjust sensor default values and continue operation.
	Sensor signal too low	P0666				
	ECU temperature warning	P1603				Warning indication only.
ECU supply voltage	Supply voltage too low	P0560				Warning indication only.
	Supply voltage too high	P0560				Warning indication only.
	Supply voltage illegal shut down	P1240				Warning output only at the time of the engine restart.

Part	Factor (DTC Description)	DTC	Failsafe action			
			Max speed derate	Max torque derate	ENG Stop	Others
Sensor power supply 1	Supply voltage too high	P0641				Sensor 5V-1 too low: Switching PC1 sensor to PC2 sensor. Sensor 5V-2 too low: Maximum speed is reduced, because boost pressure sensor voltage is not correct.
	Supply voltage too low					
Sensor power supply 2	Supply voltage too high	P0651				Maximum speed is reduced, because boost pressure sensor voltage is not correct.
	Supply voltage too low					
Cam sensor (G1 sensor) (main)	Disconnection / Sensor failure	P0016				If one of the main crank or cam sensors have failed, the sensor system moves to the back up system and can operate the engine normally. While operating using the back up sensor system, the engine will stop if the crank sensor fails. The engine will operate, but can not re-start, if the cam sensor fails.
	Intermittent disconnection / Noise	P0340				
	Disconnection / Sensor failure	P0340				
Crank sensor (NE1 sensor) (main)	Disconnection / Sensor failure	P0017				
	Intermittent disconnection / Noise	P0335				
Both main sensor	Disconnection / Sensor failure	P0008				
Cam sensor (G2 sensor) (backup)	Disconnection / Sensor failure	P0018				
	Intermittent disconnection / Noise	P0390				
	Disconnection / Sensor failure	P0390				
Crank sensor (NE2 sensor) (backup)	Disconnection / Sensor failure	P0019				
	Intermittent disconnection / Noise	P0385				
Both backup sensor	Disconnection / Sensor failure	P0009				

TROUBLESHOOTING

Part	Factor (DTC Description)	DTC	Failsafe action			
			Max speed derate	Max torque derate	ENG Stop	Others
Supply pump	Pump over supply	P0148				Warning indication only.
	Pump over supply (High press.)	P0148				Warning indication only.
	Pump no supply (or pressure control limiter is actuated)	P0148	X	X		
	Pump no supply (or fuel flow out)	P0093			X	
	Pump feedback value for ECU increasing	P0149				Warning indication only.
PCV failure	PCV short circuit to +B	P0627	X	X		
	PCV1 and 2 short circuit to +B	P2632			X	
	PCV short circuit to GND or open	P0627	X	X		
	PCV1 and 2 short circuit to GNE or open	P2632			X	

Part	Factor (DTC Description)	DTC	Failsafe action			
			Max speed derate	Max torque derate	ENG Stop	Others
EDU - INJ	Injector disconnection	P0201 (No.6) (Anti-flywheel side) P0202 (No.3) P0203 (No.5) P0204 (No.1) (Flywheel side) P0205 (No.4) P0206 (No.2)	X	X		After limiting the speed and the highest torque, stop all electricity to the injectors of a failed cylinder group. Cylinder group construction: Group 1: Cylinder 1, 2 and 3. Group 2: Cylinder 4, 5 and 6.
	COM system +B short circuit	P2148 (COM1) P2151 (COM2)	X	X		
	COM system GND short circuit or disconnection	P2146 (COM1) P2149 (COM2)	X	X		
	Injector failure (Flow damper)	P0263 (No.6) (Anti-flywheel side) P0266 (No.3) P0269 (No.5) P0272 (No.1) (Flywheel side) P0275 (No.4) P0278 (No.2)	X	X		
Main relay	Main relay contact fixed	P0686				Warning indication only.
Over revolution	Over revolution	P0219			X	
EEPROM	Abnormalities in data	P0601	X	X		Stop reading out the data memorized in the EEPROM. Adjust the default values instead and continue driving.
ROM	Abnormalities in ROM data	P0605			X	

TROUBLESHOOTING

Part	Factor (DTC Description)	DTC	Failsafe action			
			Max speed derate	Max torque derate	ENG Stop	Others
QR correction value	Abnormalities in QR check sum	P1602	X	X		
	Abnormalities in correction value upper / lower limit	P0602		X		
	Correction data un-writing	P1602		X		
Disconnection	PCV relay 1 disconnection	P1225	X	X		1 relay is disconnected: Maximum engine speed and power will be reduced. 2 relays are disconnected: Engine is stop.
	PCV relay 2 disconnection	P1226	X	X		
	EDU relay disconnection	P0612			X	
Overcurrent	Intake heater relay 1	P0380				Shut down the electricity.

SPECIFICATIONS

PRINCIPAL ENGINE SPECIFICATIONS 6CX530 Engine Specifications

Engine Model		6CX530
Marine Gear Model		KMH70A
Use		Pleasure use
Type		Vertical water cooled 4-cycle diesel engine
Aspiration		Turbocharged
Combustion System		Direct injection
Number of Cylinders		6
Bore x Stroke		110 x 130 mm (4.33 x 5.12 in.)
Displacement		7.413 L (452.37 cu in.)
Continuous Output Rating at Crankshaft	Output at Crankshaft / Engine Speed	355 kW (482.7 hp metric) / 2809 rpm *
Maximum Output Rating	Output at Crankshaft / Engine Speed	390 kW (530 hp metric) / 2900 rpm*
High Idling Speed		3100 ± 25 rpm
Low Idling Speed		650 ± 25 rpm
Installation		Flexible mounting
Fuel Injection Timing		Variable
Fuel Injection Opening Pressure		Variable (Maximum 160 MPa [23200 psi])
Main Power Take Off		At flywheel end
Direction of Rotation	Crankshaft	Counterclockwise viewed from flywheel end
	Propeller Shaft (Ahead)	Clockwise viewed from propeller end
Cooling System		Fresh water cooling with heat exchanger
Coolant Capacity		Engine: 28 L (7.4 gal.), Coolant recovery tank: 3.4 L (3.6 qt)
Lubrication System		Complete enclosed forced lubrication system
Engine Oil Capacity	Rake angle	0°
	Total**	18.8 ± 0.3 L (19.9 ± 0.3 qt)
	Effective***	8 L (8.5 qt)

SPECIFICATIONS

Engine Model		6CX530
Normal Oil Pressure Range @ 2900 rpm		0.56 MPa (81.2 psi)
Starting System	Type	Electric
	Starting Motor	DC 12 V - 4.8 kW (DC 24 V - 4.0 kW Optional)
	AC Generator	12 V - 120 A (24 V - 60 A Optional)
Turbocharger	Model	HOLSET HX50
Engine Dimension without Marine Gear	Overall Length	1674.3 mm (65.92 in.)
	Overall Width	856.5 mm (33.72 in.)
	Overall Height	933.5 mm (36.75 in.)
Flywheel Major Dimension		D392 x 80 mm (15.43 x 80 in.) (Bell housing: SAE#3, Clutch size: SAE11-1/2)
Engine Dry Mass (without Marine Gear)		837 kg (1845 lb)
Minimum Battery Capacity		12 V, 200 Ah (5 hours capacity) (24 V, 2 x 120 Ah Optional) (Flood Type : Recommended, AGM and GEL type : not recommended)

* Rating Condition: Temperature of fuel; 40°C at fuel pump inlet; ISO 8665

** The "total" oil quantity includes oil in oil pan, channels, coolers and filter.

*** The effective amount of oil shows the difference in maximum scale of the dipstick and minimum scale.

Note: Density of fuel: 0.842g/cm³ at 15°C. Fuel temperature at the inlet of the fuel injection pump.
1 hp metric = 0.7355 kW

6CX530 Marine Gear Specifications

Model	KMH70A
Down angle	7°
Type	Hydraulic wet multiple disk clutch
Reduction Ratio (Forward / Reverse)	2.56, 2.07, 1.54, 1.23/2.56, 2.07, 1.54, 1.23
Propeller Speed (Forward / Reverse) (rpm) *	1097, 1357, 1824, 2284/1097, 1357, 1824, 2284
Lubrication system	Gear pump
Lubrication oil	API CD, CF, CF-4, CI, CI-4, SAE #30
Lubricating oil capacity (Total)	7.5 L (7.9 qt)
Lubricating oil capacity (Effective)	0.5 L (0.5 qt)
Cooling system	Seawater cooling
Weight	77 kg (170 lb)

* At continuous power engine speed 2809 rpm

SYSTEM DIAGRAMS

PIPING DIAGRAMS

Notation	Item
SGP	Gas Pipe
RH	Rubber Hose
STS	Steel Pipe
STPG	Steel Pipe
— —	Screw Joint (Union)
— —	Flange or Bend Joint
—T—	Screw Joint (Rectangular)
—<—	Insertion Joint
-----	Drilled Hole
-----	Coolant Piping
-----	Coolant Piping
-----	Engine Oil Piping
-----	Diesel Fuel Piping

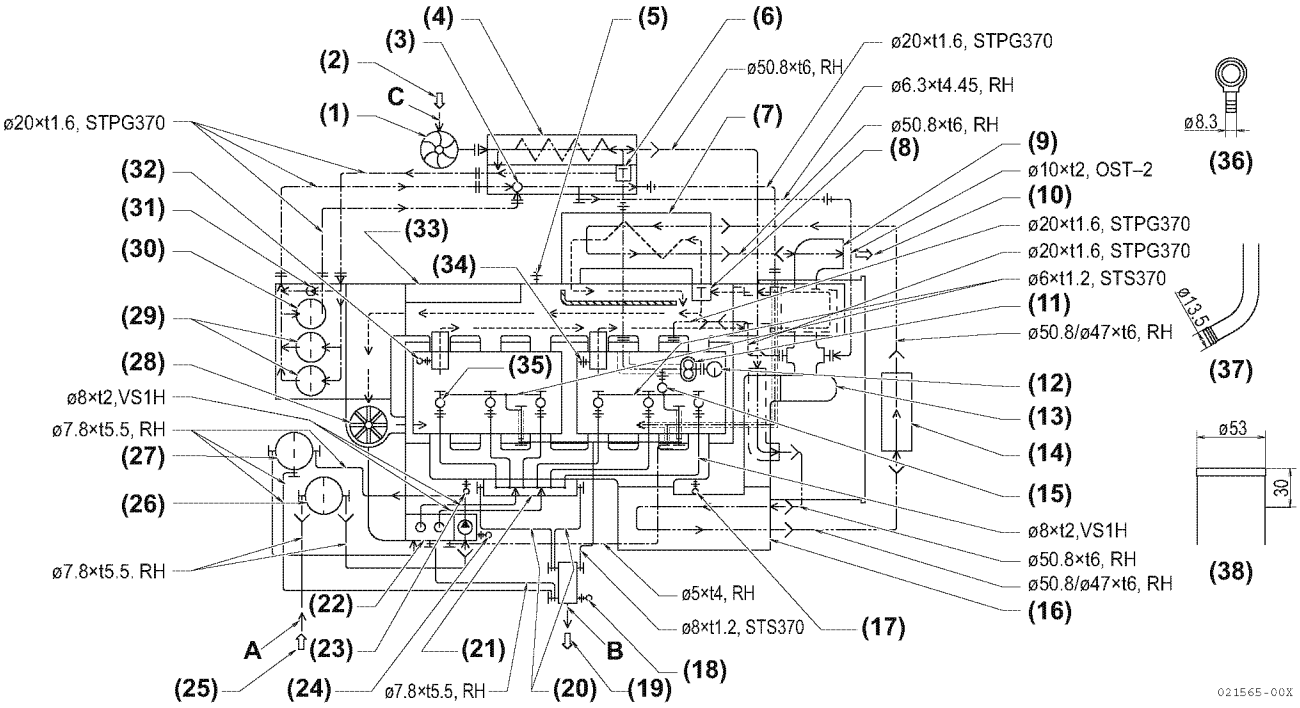

Figure 1

Note: Dimension of steel and copper pipes show O.D. \varnothing x t, dimension of rubber hoses show I.D. \varnothing x t.

1	Cooling Seawater Pump
2	Cooling Seawater Inlet
3	Oil Pressure Regulator Valve
4	Oil Cooler
5	Water Return from Water Heater
6	Thermostat
7	Heat Exchanger
8	Thermostat
9	Mixing Elbow (Not Supplied by Yanmar)
10	Cooling Seawater Outlet
11	Oil Pump
12	Oil Inlet Filter
13	Turbocharger
14	Marine Gear Oil Cooler
15	Safety Valve
16	Intercooler
17	Intake Air Temperature Sensor
18	Fuel Temperature Sensor, Fuel Outlet
19	Fuel Overflow
20	Double Wall Steel Pipe
21	Common Rail
22	Fuel Feed Pump
23	Boost Pressure Sensor
24	Fuel Temperature Sensor, Fuel Inlet
25	Fuel Inlet
26	Fuel / Water Separator (Optional)
27	Fuel Main Filter
28	Coolant Pump
29	Lubricating Oil Filter (Full)
30	Lubricating Oil Filter (Bypass)
31	Relief Valve
32	Coolant Temperature Sensor
33	Coolant Expansion Tank
34	Water Heater Outlet
35	Injector
36	Detail of Part A
37	Detail of Part B
38	Detail of Part C

WIRING DIAGRAMS

6CX530-Type Instrument Panel

6CX530 Instrument Panel are available for 12V standard and 24V optional.

For the 6CX530-type Instrument Panel wiring diagrams, please contact your authorized Yanmar Marine dealer or distributor, or refer to the relevant *Installation Manual* or *Service Manual*.

EPA WARRANTY USA ONLY

YANMAR CO., LTD. LIMITED EMISSION CONTROL SYSTEM WARRANTY - USA ONLY

The following EPA Warranty only applies to engines built on or after January 01, 2008 and labeled with the proper nameplate (Figure 1).

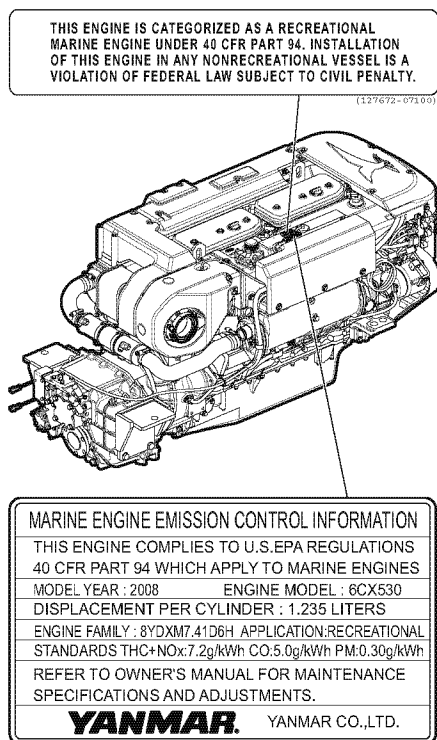

Figure 1

THIS EMISSION WARRANTY APPLIES TO THE ENGINES CERTIFIED TO UNITED STATES EPA 40 CFR 94 AND SOLD BY YANMAR THAT ARE INSTALLED IN VESSELS FLAGGED OR REGISTERED IN THE UNITED STATES.

Your Warranty Rights and Obligations:

Yanmar warrants to the first user and each subsequent purchaser the emission control system on your engine for periods of time listed below provided the engine has been installed according to Yanmar installation requirements and there has been no abuse, neglect, or improper maintenance of your Yanmar Marine engine.

Yanmar warrants that the engine is designed, built and tested using genuine parts and equipped so as to conform to all applicable emission requirements of the U.S. Environmental Protection Agency and is free from defects in material and workmanship which would cause this engine to fail to conform to the applicable emission regulations over its limited emission control system warranty period.

Where a warrantable emissions condition exists, Yanmar will repair your engine at no charge to you for diagnosis, parts, and labor. Warranty service or repair will be provided at authorized Yanmar Marine dealers or distributors.

It is recommended that any replacement parts used for maintenance, repair or replacement of emission control systems are Yanmar parts. The owner may elect to have maintenance, replacement or repair of the emission control components and systems performed by any repair establishment or individual and may elect to use parts other than Yanmar parts for such maintenance, replacement or repair. However, the cost of such service or parts and subsequent failures from such service or parts will not be covered under this emission control system warranty:

Warranty Period:

The warranty starts on either the date of delivery to the first end-user, or the date the unit is first leased, rented, or loaned.

For Pleasure Use: The warranty period is **five (5) years or 2000 hours** of use, whichever occurs first. In the absence of a device to measure hours of use, the engine has a warranty period of **five (5) years**.

Warranty Coverage:

Repair or replacement of any warranted parts will be performed at an authorized Yanmar Marine dealer or distributor. This limited emission control system warranty covers engine components that are a part of the emission control system of the engine as delivered by Yanmar to the original retail purchaser. Such components may include the following:

1. Fuel Injection System
2. Turbocharger System
3. Aftercooler
4. Electronic Engine Control Units and its associated Sensor and Actuators

Exclusions:

Failures other than those arising from defects in material and / or workmanship are not covered by this limited emissions warranty. This warranty does not extend to the following: malfunction caused by abuse, misuse, improper adjustment, modification, alteration, tampering, disconnection, improper or inadequate maintenance, improper storage or use of non-recommended fuels and lubricating oils, accident-caused damage, and replacement of expendable and / or consumable items made in connection with scheduled maintenance.

Yanmar disclaims any responsibility for incidental or consequential damages such as loss of time, inconvenience, loss of use of marine vessel / engine or commercial loss.

Owner's Responsibility:

As the Yanmar Marine engine owner, you are responsible for the performance of the required maintenance listed in your *Operation Manual*. Yanmar recommends that you retain all documentation, including receipts, covering maintenance on your marine engine, but Yanmar cannot deny warranty solely for the lack of receipts or for your failure to ensure the performance of all scheduled maintenance.

Your engine is designed to operate on diesel fuel only. Use of any other fuel may result in your engine no longer operating in compliance with applicable emission requirements. You are responsible for initiating the warranty process. You must present your marine engine to an authorized Yanmar Marine dealer or distributor as soon as a problem exists.

Customer Assistance:

If you have any questions regarding your warranty rights and responsibilities or would like information on the nearest authorized Yanmar Marine dealer or distributor, you should contact Yanmar Marine USA Corporation for assistance.

Yanmar Marine USA Corporation

101 International Parkway
Adairsville, GA 30103 USA
Telephone: 770-877-9894
Fax: 770-877-7567

EPA WARRANTY USA ONLY

Maintenance Log

Date	Operating Hours	Maintenance Performed	Dealer Name	Stamp or Signature

1307

Date	OperatingHours	Maintenance Performed	Dealer Name	Stamp or Signature

Declaration of Conformity for Recreational Craft Propulsion Engine with the Exhaust emission requirements of Directive 94/25/EC as amended by 2003/44/EC (To be completed by manufacturer of inboard engines without integral exhaust)

Name of engine manufacturer: Yanmar Co., Ltd.

Street: 1-32 Town: Chayamachi, Kitaku, Osaka-City

Post Code: 530-8311 Country: Japan

Name of Authorised Representative: Yanmar Marine International B.V.

Street: Brugplein 11 Town: Almere-de Vaart

Post Code: 1332 BS Country: The Netherlands

Name of Notified Body for exhaust emission assessment: Société Nationale de Certification et d'Homologation

Street: 11, route de Luxembourg Town: Sandweiler

Post Code: L-5230 Country: Luxembourg ID Number: 0499

Module used for exhaust emission assessment: B+C B+D B+E B+F G H
 or engine type-approved according to: stage II of Directive 97/68/EC Directive 88/77/EC
 Other Community Directives applied: 89/336/EEC

DESCRIPTION OF ENGINE(S) AND ESSENTIAL REQUIERMENTS

Engine Type: z or sterndrive without integral exhaust Inboard engine
 Fuel Type: Diesel Petrol
 Combustion cycle: 2 stroke 4 stroke

Essential requirements	Standards Used	Other normative document used	See technical file
Annex I.B – Exhaust Emissions			
engine identification			
exhaust emission requirements	EN ISO 8178-1:1996		X
durability			
owner's manual			
Annex I.C – Noise Emissions	see craft manufacturer's Declaration of Conformity		

ENGINE(S) COVERED BY THIS DECLARATION

Engine model(s) or engine family name(s):	EC Type certificate number (exhaust)
	SNCH*94/25*2003/44*
RCD-1GM10X1	0009*00
RCD-2YM15X1	0004*00
RCD-3YM30X1	0005*00
RCD-4JH4X1	0014*00
RCD-4JH3TX1	0011*01
RCD-4LHAX1	0015*00
RCD-6LPADX1	0012*00
RCD-6LPASX1	0007*00
RCD-6CXMX1	0006*00
RCD-6LY2X1	0008*00
RCD-6LY3X1	0010*01
RCD-4JH3TX2	0016*00
RCD-4JH4TX2	0017*00
RCD-4JH4TX1	0018*00
RCD-6LPASX2	0023*00
RCD-4JH4AX1	0025*00
RCD-6CX53X1	0028*00

I declare on behalf of the engine manufacturer that the engine(s) will meet the exhaust emission requirements of Directive 94/25/EC as amended by Directive 2003/44/EC when installed in a recreational craft, in accordance with the engine manufacturer's supplied instructions and that this (these) engine(s) must not be put into service until the recreational craft into which it is (they are) to be installed has been declared in conformity with the relevant provisions of the above mentioned Directive.

Name: Mitsuo Kaji Signature and title: M. Kaji
 (identification of the person empowered to sign on behalf of the engine manufacturer or his authorised representative) (or an equivalent marking) Manager

Date: (yr/month/day) 2008 / 4 / 16

YMI Development Dept.
 Development Dept.
 Marine Operations Dept.
 Yanmar Co., Ltd.



Yanmar Marine International B.V.

P.O. Box 30112, 1303AC Almere, The Netherlands
Brugplein 11, 1332 BS Almere-De Vaart, The Netherlands
Phone: +31 36-5493200
Fax: +31 36-5493209

Yanmar Co., Ltd

Head Office

1-32, Chayamachi, Kita-Ku, Osaka 530-8311, Japan

Yanmar America Corporation (Marine Business Unit)

101 International Parkway, Adairsville, GA 30103, USA
Phone: +1 770-877-9894
Fax: +1 770-877-9009

Yanmar Asia (Singapore) Corporation Pte Ltd.

4 Tuas Lane. Singapore 638613
Phone: +65 6861-3855
Fax: +65 6862-5195

Dealer Network: www.yanmarmarine.com

