



YANMAR
®

6SY
series
OPERATION MANUAL

P/N 0A6301-G0000

**MARINE
ENGINES**

Disclaimers:

We reserve the right to change specifications and to improve our products without notice or obligation.

Yanmar and **YANMAR** are registered trademarks of Yanmar Co., Ltd. in Japan, the United States and / or other countries.

All Rights Reserved:

No part of this publication may be reproduced or used in any form by any means - graphic, electronic, or mechanical, including photocopying, recording, taping, or information storage and retrieval systems - without the written permission of Yanmar Marine International.

© 2005 Yanmar Marine International.

INTRODUCTION

Welcome to the world of Yanmar Marine! Yanmar Marine offers engines, drive systems and accessories for all types of boats, from runabouts to sailboats, and from cruisers to mega yachts. In marine leisure boating, the worldwide reputation of Yanmar Marine is second to none. We design our engines to respect nature. This means quieter engines, with minimal vibrations, cleaner than ever. All of our engines designed after 1996 meet most of the present and future emission regulations, such as BSO II, SAV, EPA II, IMO and RCD.

To help you enjoy your Yanmar 6SY engine for many years to come, please follow these recommendations:

- Read and understand this Operation Manual before you operate the machine to ensure that you follow safe operating practices and maintenance procedures.
- Keep this Operation Manual in a convenient place for easy access.
- If this Operation Manual is lost or damaged, order a new one from your authorized Yanmar marine dealer or distributor.
- Make sure this manual is transferred to subsequent owners. This manual should be considered a permanent part of the engine and remain with it.
- Constant efforts are made to improve the quality and performance of Yanmar products, so some details included in this Operation Manual may differ slightly from your engine. If you have any questions about these differences, please contact your authorized Yanmar marine dealer or distributor.
- The specifications and components (instrument panel, fuel tank, etc.) described in this manual may differ from ones installed on your vessel. Please refer to the manual provided by the manufacturer of these components.

INTRODUCTION

RECORD OF OWNERSHIP

Take a few moments to record the information you need when you contact Yanmar for service, parts or literature.

Engine Model: _____

Engine Serial No.: _____

Date Purchased: _____

Dealer: _____

Dealer Phone: _____

TABLE OF CONTENTS

	Page
Introduction	iii
Table of Contents	v
Safety	1
Safety Precautions	2
Before You Operate	2
During Operation and Maintenance	3
Product Overview	19
Yanmar 6SY Features and Applications	19
NamePlate	21
Engine Nameplate (Typical)	21
Engine Management System (EMS S6)	23
Rotation Speeds	24
Redundant Throttle Mode	24
Coolant Temperature	24
Oil Pressure	25
Before You Operate	27
Diesel Fuel	33
Diesel Fuel Specifications	33
Additional Technical Fuel Requirements	33
Diesel Fuel Lines	34
Filling the Fuel Tank	34
Bleeding the Fuel System	36

TABLE OF CONTENTS

Engine Oil	37
Engine Oil Specifications	38
Service Categories	38
Definitions	38
Additional Technical Engine Oil Requirements:	38
Engine Oil Viscosity	38
Maximum Angles of Inclination During Operation	39
Checking Engine Oil	39
Adding Engine Oil	40
Selection of Marine Gear Oil	40
Engine Coolant	40
Engine Coolant Specifications	41
Coolant (Closed Cooling System)	41
Checking the Coolant Level	42
Daily Checks	44
Visual Checks	44
Check Diesel Fuel, Engine Oil, and Engine Coolant Levels	45
Checking and Refilling Marine Gear Oil	45
Checking the Battery Electrolyte Level	45
Checking the Alternator Belt	45
Checking the Alarm Indicators	45
Preparing Fuel, Oil and Coolant in Reserve	45
Engine Operation	47
Starting Engine	57
Starting at Low Temperatures	57
Shutting Down the Engine	57
Checking the Engine After Operation	58
Periodic Maintenance	59
Safety Precautions	59
Before You Operate	59
During Operation and Maintenance	60
Precautions	74
The Importance of Periodic Maintenance	74
Performing Periodic Maintenance	75
The Importance of Daily Checks	75
Keep a Log of Engine Hours and Daily Checks	75
Yanmar Replacement Parts	75
Tools Required	75

Ask Your Authorized Yanmar Marine Dealer or Distributor For Help	75
Required EPA Maintenance USA Only	76
EPA Requirements USA Only	76
EPA Requirements.....	76
Conditions to Ensure Compliance with EPA Emission Standards.....	76
Inspection and Maintenance.....	77
Tightening Fasteners.....	77
Periodic Maintenance Schedule	78
Engines with Low Operating Hours	78
Inspection and Maintenance of EPA Emission-Related Parts.....	80
Periodic Maintenance Procedures.....	81
After Initial 50 Hours of Operation.....	81
Replace Engine Oil and Engine Oil Filter Element.....	81
Clean the Centrifugal Engine Oil Cleaner	83
Functional Inspection.....	85
Check and Adjust the Alternator Belt....	86
Check Electronic Management System (EMS) Operation.....	86
Adjust Propeller Shaft Alignment.....	86
Replace the Closed Crankcase Ventilation Filter Element.....	87
Every 50 Hours of Operation.....	89
Drain or Replace the Fuel Filter Element and Fuel Filter / Water Separator	89
Check the Battery Electrolyte Level (Servicable Batteries Only)	91
Every 250 Hours of Operation.....	93
Adjust the Intake / Exhaust Valve Clearance	93
Check and Adjust the Unit Injector Rocker Arms	93
Drain the Fuel Tank	93
Check or Replace the Anodes (Engines with Heat Exchangers).....	94
Replace the Air Intake Filter	94
Clean the Turbocharger.....	95
Clean the Charge Air Cooler.....	95

TABLE OF CONTENTS

Check the Wiring Connectors	97
Tighten All Major Nuts and Bolts	97
Check or Replace Flexible Engine Mounts	97
Drain, Flush, and Refill the Engine Coolant	97
Clean the Coolant System	99
Every 500 Hours of Operation	104
Check or Replace the Seawater Pump Impeller (Engines with Heat Exchanger)	104
Every 1000 Hours of Operation	105
Check the Unit Injector Spray Pattern	105
Adjust Unit Injectors	105
Replace Flexible Engine Mounts	105
Every 2000 Hours of Operation	105
Overhaul and Check Fuel Feed Pump	105
Clean Engine Oil Cooler	105
Check the Battery Charge	106
Replace the Battery	107
Check for Leakage of Fuel, Engine Oil and Engine Coolant	108
Clean the Battery	110
Long-Term Storage	113
Specifications	115
Principal Engine Specifications	115

SAFETY

Yanmar considers safety of great importance and recommends that anyone that comes into close contact with its products, such as those who install, operate, maintain or service Yanmar products exercise care, common sense and comply with the safety information in this manual and on the machine's safety labels. Keep the labels from becoming dirty or torn and replace them if they are lost or damaged. Also, if you need to replace a part that has a label attached to it, make sure you order the new part and label at the same time.



This safety alert symbol appears with most safety statements. It means attention, become alert, your safety is involved! Please read and abide by the message that follows the safety alert symbol.

DANGER

Danger (the word “DANGER” is in white letters with a red rectangle behind it) – indicates an imminently hazardous situation which, if not avoided, will result in death or serious injury. Danger is limited to the most extreme situations.

000001en

WARNING

Warning (the word “WARNING” is in black letters with an orange rectangle behind it) – indicates a potentially hazardous situation which, if not avoided, could result in death or serious injury.

000001en

CAUTION

Caution (the word “CAUTION” is in black letters with a yellow rectangle behind it) – indicates a potentially hazardous situation which, if not avoided, may result in minor or moderate injury.

000001en

CAUTION

Caution *without the safety alert symbol* indicates a potentially hazardous situation that can cause damage to the engine, personal property and / or the environment or cause the engine to operate improperly.

000001enMarine

SAFETY PRECAUTIONS

Before You Operate

CAUTION







NEVER permit anyone to install or operate the engine without proper training.

- Read and understand this Operation Manual before you operate or service the engine to ensure that you follow safe operating practices and maintenance procedures.
- Safety signs and labels are additional reminders for safe operating and maintenance techniques.
- See your authorized Yanmar marine dealer or distributor for additional training.

000002enMarine

During Operation and Maintenance

 DANGER	
	
EXPLOSION HAZARD!	
<ul style="list-style-type: none">• Keep the area around the battery well-ventilated. While the engine is running or the battery is charging, hydrogen gas is produced which can be easily ignited.• Keep sparks, open flame and any other form of ignition away while the engine is running or battery is charging.• Failure to comply will result in death or serious injury.	
000003en	

 DANGER	
	
SCALD HAZARD!	
<ul style="list-style-type: none">• NEVER remove the coolant filler cap if the engine is hot. Steam and hot engine coolant will escape and seriously burn you. Allow the engine to cool sufficiently before attempting to remove the filler cap.• Securely tighten the filler cap after checking the coolant level. Steam can escape during engine operation if the cap is loose.• Failure to comply will result in death or serious injury.	
000002enMarine	

⚠ DANGER



FIRE AND EXPLOSION HAZARD!

- Diesel fuel is flammable and explosive under certain conditions.
- When you remove any fuel system component to perform maintenance (such as changing the fuel filter) place an approved container under the opening to catch the fuel.
- NEVER use a shop rag to catch the fuel. Vapors from the rag are flammable and explosive.
- Wipe up any spills immediately.
- Wear eye protection. The fuel system is under pressure and fuel could spray out when you remove any fuel system component.
- Failure to comply will result in death or serious injury.

000009en

⚠ DANGER



FIRE AND EXPLOSION HAZARD!

- Diesel fuel is flammable and explosive under certain conditions.
- NEVER use diesel fuel as a cleaning agent.
- Failure to comply will result in death or serious injury.

0000012en

⚠ DANGER



FIRE AND EXPLOSION HAZARD!

- Diesel fuel is flammable and explosive under certain conditions.
- NEVER remove the fuel cap with the engine running.
- Failure to comply will result in death or serious injury.

0000011en

⚠ DANGER**FIRE AND EXPLOSION HAZARD!**

- Only use the key switch to start the engine.
- **NEVER** jump start the engine. Sparks caused by shorting the battery to the starter terminals may cause a fire or explosion.
- Failure to comply will result in death or serious injury.

000004en

⚠ DANGER**FIRE AND EXPLOSION HAZARD!**

- Diesel fuel is flammable and explosive under certain conditions.
- Only fill the fuel tank with diesel fuel. Filling the fuel tank with gasoline may result in a fire and will damage the engine.
- **NEVER** refuel with the engine running.
- Wipe up all spills immediately.
- Keep sparks, open flames or any other form of ignition (match, cigarette, static electric source) well away when refueling.
- **NEVER** overfill the fuel tank.
- Fill the fuel tank. Store any containers containing fuel in a well-ventilated area, away from any combustibles or sources of ignition.
- Failure to comply will result in death or serious injury.

000005en

⚠ DANGER



FIRE AND EXPLOSION HAZARD!

- Diesel fuel is flammable and explosive under certain conditions.
- Before you operate the engine, check for fuel leaks. Replace rubberized fuel hoses every two years or every 2000 hours of engine operation, whichever comes first, even if the engine has been out of service. Rubberized fuel lines tend to dry out and become brittle after two years or 2000 hours of engine operation, whichever comes first.
- Failure to comply will result in death or serious injury.

0000015en

⚠ DANGER



EXPLOSION HAZARD!

- **NEVER** check the remaining battery charge by shorting out the terminals. This will result in a spark and may cause an explosion or fire. Use a hydrometer to check the remaining battery charge.
- If the electrolyte is frozen, slowly warm the battery before you recharge it.
- Failure to comply will result in death or serious injury.

0000007en

⚠ DANGER**FIRE AND EXPLOSION HAZARD!**

- Diesel fuel is extremely flammable and explosive under certain conditions.
- When you prime the fuel system, operate the fuel priming lever of the mechanical fuel pump several times until the fuel filter cup is filled with fuel.
- NEVER open the air vent valve while the fuel system is being primed. The fuel filter has an internal air bleed port.
- Failure to comply will result in death or serious injury.

0000016en

⚠ DANGER**CRUSH HAZARD!**

- ALWAYS use the engine lifting eyes when lifting the marine engine. The lifting eyes are engineered to lift the weight of the marine engine only.
- ALWAYS use lifting equipment with sufficient capacity to lift the marine engine. Additional equipment is necessary to lift the marine engine and marine gear together.
- NEVER stand under hoisted marine engine. If the hoist mechanism fails, the marine engine will fall on you, causing serious injury or death.
- Failure to comply will result in death or serious injury.

0000026en

WARNING



SEVER HAZARD!

- Keep hands and other body parts away from moving / rotating parts such as the flywheel or PTO shaft.
- Wear tight fitting clothing and keep your hair short or tie it back while the engine is running.
- Remove all jewelry before you operate or service the engine.
- NEVER start the engine in gear. Sudden movement of the engine and / or vessel could cause death or serious personal injury.
- NEVER operate the engine without the guards in place.
- Before you start the engine make sure that all bystanders are clear of the area.
- Keep children and pets away while the engine is operating.
- Check before starting the engine that any tools or shop rags used during maintenance have been removed from the area.
- Failure to comply could result in death or serious injury.

000002enMarine

WARNING



EXHAUST HAZARD!

- NEVER operate the engine in an enclosed area such as a garage, tunnel, underground room, manhole or ship's hold without proper ventilation.
- NEVER block windows, vents, or other means of ventilation if the engine is operating in an enclosed area. All internal combustion engines create carbon monoxide gas during operation. Accumulation of this gas within an enclosure could cause illness or even death.
- Make sure that all connections are tightened to specifications after repair is made to the exhaust system.
- Failure to comply could result in death or serious injury.

000003en

⚠ WARNING**ALCOHOL AND DRUG HAZARD!**

- NEVER operate the engine while you are under the influence of alcohol or drugs.
- NEVER operate the engine when you are feeling ill.
- Failure to comply could result in death or serious injury.

000004en

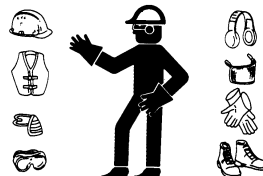
⚠ WARNING**EXPOSURE HAZARD!**

- Wear personal protective equipment such as gloves, work shoes, eye and hearing protection as required by the task at hand.
- NEVER wear jewelry, unbuttoned cuffs, ties or loose fitting clothing when you are working near moving / rotating parts such as the flywheel or PTO shaft.
- ALWAYS tie back long hair when you are working near moving / rotating parts such as a flywheel or PTO shaft.
- NEVER operate the engine while wearing a headset to listen to music or radio because it will be difficult to hear the warning signals.
- Failure to comply could result in death or serious injury.

000005enMarine

WARNING

SUDDEN MOVEMENT HAZARD!

- Be sure the boat is in open water away from other boats, docks, and other obstructions before increasing rpm.
- Failure to comply could result in death or serious injury.

000006enMarine

WARNING



BURN HAZARD!

- Batteries contain sulfuric acid. NEVER allow battery fluid to come in contact with clothing, skin or eyes. Severe burns could result. ALWAYS wear safety goggles and protective clothing when servicing the battery. If battery fluid contacts the eyes and / or skin, immediately flush the affected area with a large amount of clean water and obtain prompt medical treatment.
- Failure to comply could result in death or serious injury.

000007en

WARNING



HIGH PRESSURE HAZARD!

- Avoid skin contact with high pressure diesel fuel spray caused by a fuel system leak such as a broken fuel injection line. High pressure fuel can penetrate your skin and result in serious injury. If you are exposed to high pressure fuel spray, obtain prompt medical treatment.
- NEVER check for a fuel leak with your hands. ALWAYS use a piece of wood or cardboard. Have your authorized Yanmar marine dealer or distributor repair the damage.
- Failure to comply could result in death or serious injury.

000008enMarine

⚠ WARNING**SHOCK HAZARD!**

- Turn off the battery switch (if equipped) or disconnect the negative battery cable before servicing the electrical system.
- Check the electrical harnesses for cracks, abrasions, and damaged or corroded connectors. **ALWAYS** keep the connectors and terminals clean.
- Failure to comply could result in death or serious injury.

000009en

⚠ WARNING**WELDING SHOCK HAZARD!**

- Turn off the battery switch (if equipped) or disconnect the negative battery cable and the leads to the alternator when welding on the vessel.
- Remove the multi-pin connector to the engine control unit. Connect the weld clamp to the component to be welded and as close as possible to the welding point.
- **NEVER** connect the weld clamp to the engine or in a manner which would allow current to pass through a mounting bracket.
- When welding is completed, reconnect the leads to the alternator and engine control unit prior to reconnecting the batteries.
- Failure to comply could result in death or serious injury.

0000117en

WARNING



ENTANGLEMENT HAZARD!

- Stop the engine before you begin to service it.
- **NEVER** leave the key in the key switch when you are servicing the engine. Someone may accidentally start the engine and not realize you are servicing it. This could result in a serious injury.
- If you must service the engine while it is operating, remove all jewelry, tie back long hair, and keep your hands, other body parts and clothing away from moving / rotating parts.
- Failure to comply could result in death or serious injury.

0000010en

WARNING



BURN HAZARD!

- Wait until the engine cools before you drain the engine coolant. Hot engine coolant may splash and burn you.
- Failure to comply could result in death or serious injury.

0000016en

WARNING



BURN HAZARD!

- If you must drain the engine oil while it is still hot, stay clear of the hot engine oil to avoid being burned.
- **ALWAYS** wear eye protection.
- Failure to comply could result in death or serious injury.

0000011en

WARNING



BURN HAZARD!

- Wait until the engine cools before draining seawater from the cooling system. Hot seawater may splash and burn you.
- Failure to comply could result in death or serious injury.

0000016enMarine

⚠ WARNING**BURN HAZARD!**

- Keep your hands, and other body parts, away from hot engine surfaces such as the muffler, exhaust pipe, turbocharger (if equipped) and engine block during operation and shortly after you shut the engine down. These surfaces are extremely hot while the engine is operating and could seriously burn you.
- Failure to comply could result in death or serious injury.

0000015en

⚠ CAUTION**COOLANT HAZARD!**

- Wear eye protection and rubber gloves when you handle Long Life engine coolant. If contact with the eyes or skin should occur, flush eyes and wash immediately with clean water.
- Failure to comply may result in minor or moderate injury.

0000005enMarine

⚠ WARNING**FIRE HAZARD!**

- Undersized wiring systems can cause an electrical fire.
- Failure to comply could result in death or serious injury.

0000027en

⚠ CAUTION**FLYING OBJECT HAZARD!**

- ALWAYS wear eye protection when servicing engine and when using compressed air or high-pressure water. Dust, flying debris, compressed air, pressurized water or steam may injure your eyes.
- Failure to comply may result in minor or moderate injury.

0000003en

CAUTION

- Only use diesel fuels recommended by Yanmar for the best engine performance, to prevent engine damage and to comply with EPA warranty requirements.
- Only use clean diesel fuel.
- NEVER remove primary strainer from the fuel tank filler port. If removed, dirt and debris could get into the fuel system causing it to clog.

000004enMarine

CAUTION

If any problem is noted during the visual check, the necessary corrective action should be taken before you operate the engine.

0000021en

CAUTION

Be sure to close the seacock. Neglecting to close the seacock could allow water to leak into the boat and may cause it to sink.

0000152en

CAUTION

The illustrations and descriptions of optional equipment in this manual, such as the operator's console, are for a typical engine installation. Refer to the documentation supplied by the optional equipment manufacturer for specific operation and maintenance instructions.

0000018en

CAUTION

If any indicator illuminates during engine operation, stop the engine immediately. Determine the cause and repair the problem before you continue to operate the engine.

0000029en

CAUTION

NEVER hold the key in the START position for longer than 15 seconds or the starter motor will overheat.

0000007en

CAUTION

Observe the following environmental operating conditions to maintain engine performance and avoid premature engine wear:

- **NEVER** run the engine if the ambient temperature is above +40°C (+104°F) or below -16°C (+5°F)
 - ◆ If the ambient temperature exceeds +40°C (+104°F) the engine may overheat and cause the engine oil to break down.
 - ◆ If the ambient temperature falls below -16°C (+5°F) rubber components such as gaskets and seals will harden causing premature engine wear and damage.
 - ◆ See your authorized Yanmar marine engine dealer or distributor if the engine will be operated in either temperature extreme.
- See your authorized Yanmar marine dealer or distributor if you need to operate the engine at high altitudes. At high altitudes the engine will lose power, run rough, and produce exhaust gases that exceed the design specifications.

0000065enMarine

CAUTION

- Only use the engine coolant specified. Other engine coolants may affect warranty coverage, cause an internal buildup of rust and scale and / or shorten engine life.
- Prevent dirt and debris from contaminating engine coolant. Carefully clean the heat exchanger cap and the surrounding area before you remove the cap.
- **NEVER** mix different types of engine coolants. This may adversely affect the properties of the engine coolant.

0000006enTrans

CAUTION

- Only use the engine oil specified. Other engine oils may affect warranty coverage, cause internal engine components to seize, or shorten engine life.
- Prevent dirt and debris from contaminating engine oil. Carefully clean the oil cap / dipstick and the surrounding area before you remove the cap.
- **NEVER** mix different types of engine oil. This may adversely affect the lubricating properties of the engine oil.
- **NEVER** overfill. Overfilling may result in white exhaust smoke, engine overspeed or internal damage.

0000005en

CAUTION

- **NEVER** overfill the engine with engine oil.
- **ALWAYS** keep the oil level between upper and lower lines on the oil cap / dipstick.

0000015en

CAUTION

For maximum engine life, Yanmar recommends that when shutting the engine down, you allow the engine to run, without load, for five minutes. This will allow the engine components that operate at high temperatures, such as the exhaust system, to cool slightly before the engine itself is shut down.

0000008enYDG

CAUTION

NEVER use an engine starting aid such as ether. Engine damage will result.

0000009en

CAUTION

Make sure the engine is installed on a level surface. If a Yanmar Marine Engine is installed at an angle that exceeds the specifications stated in the Yanmar Marine Installation manuals, engine oil may enter the combustion chamber causing excessive engine speed, white exhaust smoke and serious engine damage. This applies to engines that run continuously or those that run for short periods of time.

0000010enMarine

CAUTION

Be careful not to get any oil on the belt(s). Oil on the belt causes slipping and stretching. Replace the belt if it is damaged.

0000153enMarine

CAUTION

If seawater is left inside of the engine, it may freeze and damage parts of the cooling system when the ambient temperature is below 0°C (32°F).

0000154en

CAUTION

NEVER allow engine oil or diesel fuel oil to contact the flexible rubber mount. Oil makes rubber deteriorate.

0000155en

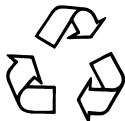
CAUTION

- **ALWAYS** be environmentally responsible.
- Follow the guidelines of the EPA or other governmental agencies for the proper disposal of hazardous materials such as engine oil, diesel fuel and engine coolant. Consult the local authorities or reclamation facility.
- **NEVER** dispose of hazardous materials irresponsibly by dumping them into a sewer, on the ground or into ground water or waterways.
- Failure to follow these procedures may seriously harm the environment.

0000013en

CAUTION

Protect the air cleaner, turbocharger (if equipped) and electric components from damage when you use steam or high-pressure water to clean the engine.

0000014en

CAUTION

If any indicator fails to illuminate when the key switch is in the ON position, see your authorized Yanmar marine dealer or distributor for service before operating the engine.

0000028enMarine

CAUTION

Establish a periodic maintenance plan according to the engine application and make sure you perform the required periodic maintenance at intervals indicated. Failure to follow these guidelines will impair the engine's safety and performance characteristics, shorten the engine's life and may affect the warranty coverage on your engine.

0000024en

CAUTION

It is important to perform daily checks as listed in the Operation Manual.

Periodic maintenance prevents unexpected downtime, reduces the number of accidents due to poor engine performance and helps extend the life of the engine.

0000060enMarine

CAUTION

If the fuel filter / water separator is positioned higher than the fuel level in the fuel tank, water may not drip out when the fuel filter / water separator drain cock is opened. If this happens, turn the air vent screw on the top of the fuel filter / water separator 2-3 turns counterclockwise.

Be sure to tighten the air vent screw after the water has drained out.

0000025en

CAUTION

NEVER turn off the battery switch (if equipped) or short the battery cables during operation. Damage to the electric system will result.

0000061en

CAUTION

- When the engine is operated in dusty conditions, clean the air cleaner element more frequently.
- **NEVER** operate the engine with the air cleaner or element(s) removed. This may allow foreign material to enter the engine and damage it.

0000026en

CAUTION

Clean or replace the air cleaner element if the air intake restriction exceeds the value listed in the Operation and Service Manuals.

0000046enMarine

PRODUCT OVERVIEW

YANMAR 6SY FEATURES AND APPLICATIONS

The 6SY is a four-stroke 6-cylinder direct injection diesel engine. The engine is turbocharged and equipped with a charge air cooler containing a liquid coolant system.

The engine has a heat exchanger which is cooled by a seawater coolant system.

The engine is designed for pleasure craft use.

The engine must be installed correctly with coolant lines, exhaust gas lines and electrical wiring. Any auxiliary equipment attached to the engine should be easy to use and accessible for service. To handle the drive equipment, propulsion systems (including the propeller) and other onboard equipment, always observe the instructions and cautions given in the operation manuals supplied by the shipyard and equipment manufacturers.

The laws of some countries may require hull and engine inspections, depending on the use, size and cruising area of the boat. The installation, fitting and surveying of this engine all require specialized knowledge and engineering skills. See Yanmar's local subsidiary in your region or your authorized Yanmar marine dealer or distributor.

COMPONENT IDENTIFICATION

Figure 1 illustrates a typical version of a 6SY engine. Your engine may have different equipment from that illustrated.

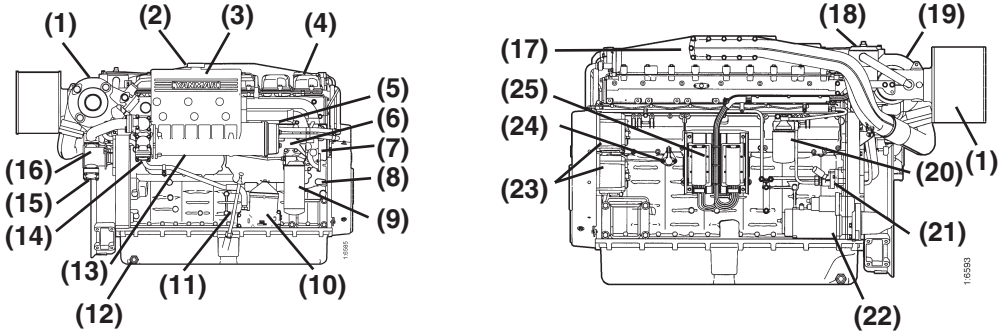

Figure 1

1. Air Filter
2. Coolant Fill Cap
3. Coolant Recovery Tank
4. Engine Oil Fill Cap
5. Engine Number, Stamped into the Engine Block
6. Nameplate
7. Coolant Pump
8. Coolant Drain
9. Engine Oil Filter
10. Engine Oil Cleaner
11. Engine Oil Dipstick
12. Engine Oil Drain
13. Heat Exchanger
14. Seawater Outlet
15. Seawater Supply
16. Seawater Pump
17. Charge Air Cooler
18. Close Crankcase Ventilation
19. Turbocharger
20. Fuel Filter
21. Fuel Pump
22. Starter Motor
23. Alternator (1 Standard, 2nd Optional)
24. Engine Oil Pressure Sensor
25. Control Unit (EMS S6)

NAMEPLATE

The following figure (**Figure 2**) shows the location of regulatory and safety labels on Yanmar 6SY marine engines.

Engine Nameplate (Typical)

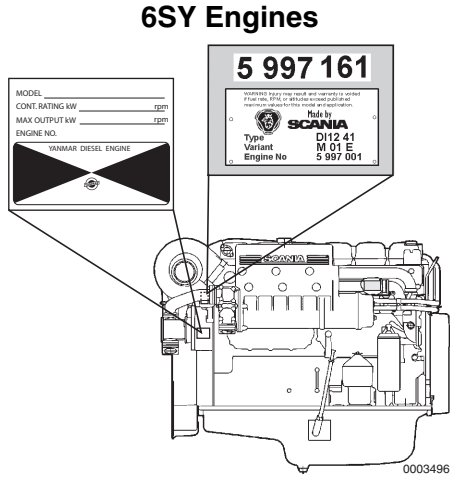

Figure 2

PRODUCT OVERVIEW

FUNCTION OF MAJOR COMPONENTS

Name of part	Function
Fuel Filter	Removes dirt and water from the fuel. Drain the filter periodically. The filter element should be replaced periodically. <i>See Drain or Replace the Fuel Filter Element and Fuel Filter / Water Separator on page 89.</i>
Fuel Feed Pump	Pumps fuel from the tank to the fuel injection system.
Engine Oil Fill Port	Fill port for engine oil.
Engine Oil Filter	Filters fine metal fragments and carbon from the engine oil. Filtered engine oil is distributed to the engine's moving parts.
Coolant System	There are two coolant systems: closed cooling with coolant and seawater. The engine's combustion heat is cooled by the closed cooling circuit. The closed circuit is cooled by seawater using a heat exchanger. The seawater also cools the engine / marine gear oil.
Heat Exchanger	The heat exchanger cools the closed cooling circuit with seawater.
Closed Cooling Circulation Pump	The centrifugal water pump circulates coolant inside the engine. The circulating pump is driven by a belt.
Seawater Pump	The rubber impeller-type pump pumps seawater for cooling. Never operate it without seawater, as this will damage the impeller.
Coolant Fill Cap	The fill cap on the coolant tank has a pressure regulating valve. When the coolant temperature rises, the pressure rises inside the fresh water system.
Coolant Recovery Tank	The pressure regulating valve releases vapor and hot water overflow to the coolant recovery tank. When the engine stops and the coolant cools, the pressure in the coolant tank drops. The fill cap valve then opens to send water back from the coolant recovery tank. This minimizes coolant consumption. The closed cooling system coolant level can easily be checked and refilled in this tank.
Oil Cooler	A heat exchanger that cools high temperature engine oil using seawater.
Turbocharger	The turbocharger pressurizes the air coming into the engine. It is driven by a turbine that is energized by exhaust gases.
Anode	The metal area of the seawater coolant system is prone to electrical corrosion. The anodes are installed to prevent this corrosion. The anodes are reduced over time by electrical corrosion and must be replaced before it is completely consumed in order to ensure that the metal area of the seawater coolant system remains fully protected.
Nameplates	Nameplates are provided on the engine and the marine gear and have the model, serial number and other data.
Starter	Starter motor for the engine. Powered by the battery.
Alternator	Driven by belt and generates electricity and charges the battery.

ENGINE MANAGEMENT SYSTEM (EMS S6)

This engine has an Electronic Management System (EMS) with unit injectors (PDE) which provide each cylinder with the right amount of fuel at the right time in all operating situations.

The EMS system consists of a control unit (S6) and sensors for speed, charge air temperature and pressure, coolant temperature, oil pressure, and throttle actuation. These sensors constantly send signals to the control unit. With this input data and the programmed control software, the correct fuel amount and correct injection time are calculated for each unit injector (PDE) under the specific operating conditions.

The EMS system sensors are also used to send signals to the digital display in the instrument panel.

The control unit constantly checks the sensors to make sure they are operational.

The control unit contains monitoring functions to protect the engine in the event of a fault which would otherwise damage it. In the event of a fault, an alarm for low oil pressure or high coolant temperature for example, the S6 control unit sends a message to the digital display.

Only authorized personnel are allowed to carry out diagnostic procedures and program changes.

The positions of the sensors which send signals to the control unit are shown (**Figure 3**).

Positions of Sensors for EMS with S6

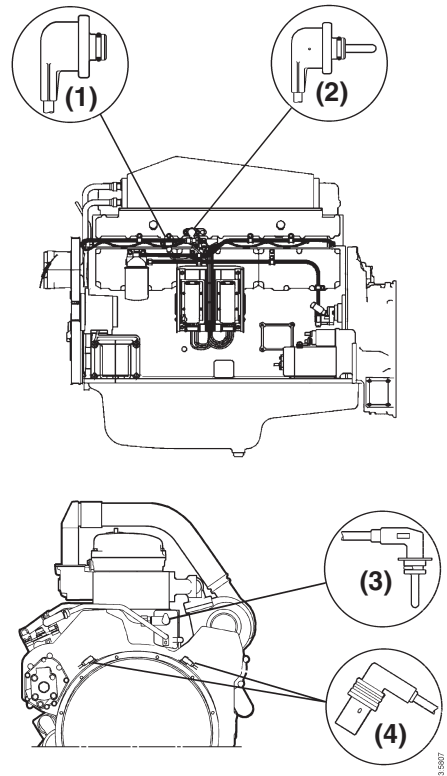

Figure 3

1. Oil Pressure Sensor
2. Charge Air Temperature and Pressure Sensor
3. Coolant Temperature Sensor
4. Engine Speed Sensors (2 used)

PRODUCT OVERVIEW

Rotation Speeds

Check instruments at regular intervals.

Rotation Speed	
0 - 500 rpm	Prohibited engine speed, passed through when stopping and starting.
500 - 700 rpm	Slow idle. Engine idling is controlled by the EMS / S6 control system.
700 - 2300 rpm	Normal operating speed. The engine operating speed range is controlled by the EMS / S6 control system.
2400 - 2600 rpm	Unsuitable operating speed.
2600 - 3000 rpm	Prohibited engine speed.

Redundant Throttle Mode

If there is a fault with the normal throttle or if CAN communication is interrupted, a redundant throttle system is provided.

In the event of a CAN open circuit or throttle fault:

- The EMS automatically switches to the redundant throttle located on the key switch panel.
- The redundant throttle must be set at zero to be activated.
- A light will illuminate on the panel indicating the redundant throttle is activated.

Coolant Temperature

Normal coolant temperature when the engine is running is 70° - 90°C (158° - 194°F).

The EMS / S6 control system has the following alarm levels:

- If the temperature is high, 98° - 103°C, (208° - 217°F) for one second, the S6 control will send a CAN message which activates a warning.
- If the temperature exceeds 103°C (217°F), a warning is activated.
- A fault code is generated in the control unit.

After an alarm, approved values must be registered for more than two seconds before resetting the alarm.

Excessively high coolant temperature can damage the engine.

If run for extended periods under an extremely light load, the engine may have difficulty in maintaining normal operating temperature. However, the temperature will rise to a normal level again when the load on the engine is increased.

Oil Pressure

The EMS has the following alarm levels:

- At a speed of less than 1000 rpm and an oil pressure of less than 1.0 bar (15 psi)
- At a speed of more than 1000 rpm and an oil pressure of less than 2.3 bar (33 psi) for longer than five seconds

The following functions are available if there is an alarm:

- Alarm which only switches on a warning.
- Alarm which switches on a warning and reduces torque if this function is activated (70% of fuel quantity).
- A fault code is generated in the control unit.

After an alarm, approved values must be registered for more than two seconds before resetting the alarm.

This Page Intentionally Left Blank

BEFORE YOU OPERATE

This section of the *Operation Manual* describes the diesel fuel, engine oil, and engine coolant specifications and how to replenish them. It also describes the daily engine checkout.

CAUTION



NEVER permit anyone to install or operate the engine without proper training.

- **Read and understand this Operation Manual before you operate or service the engine to ensure that you follow safe operating practices and maintenance procedures.**
- **Safety signs and labels are additional reminders for safe operating and maintenance techniques.**
- **See your authorized Yanmar marine dealer or distributor for additional training.**

0000002enMarine

DANGER



SCALD HAZARD!

- **NEVER** remove the coolant filler cap if the engine is hot. Steam and hot engine coolant will escape and seriously burn you. Allow the engine to cool sufficiently before attempting to remove the filler cap.
- **Securely** tighten the filler cap after checking the coolant level. Steam can escape during engine operation if the cap is loose.
- **Failure to comply will result in death or serious injury.**

000002enMarine

DANGER



FIRE AND EXPLOSION HAZARD!

- Diesel fuel is flammable and explosive under certain conditions.
- Only fill the fuel tank with diesel fuel. Filling the fuel tank with gasoline may result in a fire and will damage the engine.
- **NEVER** refuel with the engine running.
- Wipe up all spills immediately.
- Keep sparks, open flames or any other form of ignition (match, cigarette, static electric source) well away when refueling.
- **NEVER** overfill the fuel tank.
- Fill the fuel tank. Store any containers containing fuel in a well-ventilated area, away from any combustibles or sources of ignition.
- **Failure to comply will result in death or serious injury.**

000005en

⚠ DANGER**FIRE AND EXPLOSION HAZARD!**

- Diesel fuel is extremely flammable and explosive under certain conditions.
- Be sure to place the diesel fuel container on the ground when transferring the diesel fuel from the pump to the container. Hold the hose nozzle firmly against the side of the container while filling it. This prevents static electricity buildup which could cause sparks and ignite fuel vapors.
- NEVER place diesel fuel or other flammable material such as oil, hay or dried grass close to the engine during engine operation or shortly after shut down.
- Failure to comply will result in death or serious injury.

0000014en

⚠ DANGER**FIRE AND EXPLOSION HAZARD!**

- Diesel fuel is flammable and explosive under certain conditions.
- Before you operate the engine, check for fuel leaks. Replace rubberized fuel hoses every two years or every 2000 hours of engine operation, whichever comes first, even if the engine has been out of service. Rubberized fuel lines tend to dry out and become brittle after two years or 2000 hours of engine operation, whichever comes first.
- Failure to comply will result in death or serious injury.

0000015en

DANGER



FIRE AND EXPLOSION HAZARD!

- Diesel fuel is extremely flammable and explosive under certain conditions.
- When you prime the fuel system, operate the fuel priming lever of the mechanical fuel pump several times until the fuel filter cup is filled with fuel.
- NEVER open the air vent valve while the fuel system is being primed. The fuel filter has an internal air bleed port.
- Failure to comply will result in death or serious injury.

0000016en

WARNING



HIGH PRESSURE HAZARD!

- Avoid skin contact with high pressure diesel fuel spray caused by a fuel system leak such as a broken fuel injection line. High pressure fuel can penetrate your skin and result in serious injury. If you are exposed to high pressure fuel spray, obtain prompt medical treatment.
- NEVER check for a fuel leak with your hands. ALWAYS use a piece of wood or cardboard. Have your authorized Yanmar marine dealer or distributor repair the damage.
- Failure to comply could result in death or serious injury.

0000008enMarine

⚠ WARNING**BURN HAZARD!**

- If you must drain the engine oil while it is still hot, stay clear of the hot engine oil to avoid being burned.
- **ALWAYS** wear eye protection.
- Failure to comply could result in death or serious injury.

0000011en

⚠ WARNING**BURN HAZARD!**

- Wait until the engine cools before you drain the engine coolant. Hot engine coolant may splash and burn you.
- Failure to comply could result in death or serious injury.

0000016en

⚠ WARNING**BURN HAZARD!**

- Keep your hands, and other body parts, away from hot engine surfaces such as the muffler, exhaust pipe, turbocharger (if equipped) and engine block during operation and shortly after you shut the engine down. These surfaces are extremely hot while the engine is operating and could seriously burn you.
- Failure to comply could result in death or serious injury.

0000015en

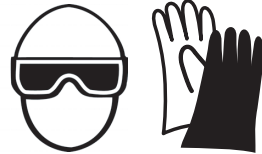
⚠ CAUTION**COOLANT HAZARD!**

- Wear eye protection and rubber gloves when you handle Long Life engine coolant. If contact with the eyes or skin should occur, flush eyes and wash immediately with clean water.
- Failure to comply may result in minor or moderate injury.

0000005enMarine

CAUTION

- Only use diesel fuels recommended by Yanmar for the best engine performance, to prevent engine damage and to comply with EPA warranty requirements.
- Only use clean diesel fuel.
- NEVER remove primary strainer from the fuel tank filler port. If removed, dirt and debris could get into the fuel system causing it to clog.

0000004enMarine

CAUTION

- Only use the engine coolant specified. Other engine coolants may affect warranty coverage, cause an internal buildup of rust and scale and / or shorten engine life.
- Prevent dirt and debris from contaminating engine coolant. Carefully clean the heat exchanger cap and the surrounding area before you remove the cap.
- NEVER mix different types of engine coolants. This may adversely affect the properties of the engine coolant.

0000006enTrans

CAUTION

- Only use the engine oil specified. Other engine oils may affect warranty coverage, cause internal engine components to seize, or shorten engine life.
- Prevent dirt and debris from contaminating engine oil. Carefully clean the oil cap / dipstick and the surrounding area before you remove the cap.
- NEVER mix different types of engine oil. This may adversely affect the lubricating properties of the engine oil.
- NEVER overfill. Overfilling may result in white exhaust smoke, engine overspeed or internal damage.

0000005en

DIESEL FUEL

Diesel Fuel Specifications

Diesel fuel should comply with the following specifications. The table lists several worldwide specifications for diesel fuels.

DIESEL FUEL SPECIFICATION	LOCATION
No. 2-D, No. 1-D, ASTM D975-94	USA
EN590:96	European Union
ISO 8217 DMX	International
BS 2869-A1 or A2	United Kingdom
JIS K2204 Grade No.2	Japan

- Carbon residue content not to exceed 0.35% by volume. Less than 0.1% is preferred.
- Total aromatics content should not exceed 35% by volume. Less than 30% is preferred.
- PAH (polycyclic aromatic hydrocarbons) content should be below 10% by volume.

Additional Technical Fuel Requirements

- The fuel cetane number should be equal to 45 or higher.
- The sulfur content must not exceed 0.5% by volume. Less than 0.05% is preferred.
- NEVER mix kerosene, used engine oil, or residual fuels with the diesel fuel.
- Water and sediment in the fuel should not exceed 0.05% by volume.
- Keep the fuel tank and fuel-handling equipment clean at all times.
- Poor quality fuel can reduce engine performance and / or cause engine damage.
- Fuel additives are not recommended. Some fuel additives may cause poor engine performance. See your authorized Yanmar marine dealer or distributor for more information.
- Ash content not to exceed 0.01% by volume.

BEFORE YOU OPERATE

Diesel Fuel Lines

Install the lines between the fuel tank and the fuel injection pump.

Be sure to install a drain cock (Figure 1, (6)) at the bottom of the fuel tank to remove water and contaminants.

Install an fuel filter / water separator (Figure 1, (3)) and a fuel filter between the fuel tank and the fuel injection pump.

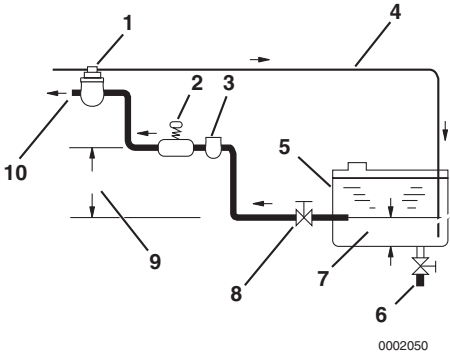

Figure 1

1. Fuel Filter
2. Fuel Priming Pump
3. Fuel Filter / Water Separator
4. Fuel Return Line
5. Fuel Tank
6. Fuel Tank Drain Cock
7. Approximately 50 mm (1.96 in.)
8. Fuel Shutoff Valve
9. Less than 500 mm (19.68 in.)
10. To Fuel Injection Pump

Filling the Fuel Tank

⚠ DANGER



FIRE AND EXPLOSION HAZARD!

- Diesel fuel is flammable and explosive under certain conditions.
- Only fill the fuel tank with diesel fuel. Filling the fuel tank with gasoline may result in a fire and will damage the engine.
- NEVER refuel with the engine running.
- Wipe up all spills immediately.
- Keep sparks, open flames or any other form of ignition (match, cigarette, static electric source) well away when refueling.
- NEVER overfill the fuel tank.
- Fill the fuel tank. Store any containers containing fuel in a well-ventilated area, away from any combustibles or sources of ignition.
- Failure to comply will result in death or serious injury.

0000005en

⚠ DANGER**FIRE AND EXPLOSION HAZARD!**

- Diesel fuel is extremely flammable and explosive under certain conditions.
- Be sure to place the diesel fuel container on the ground when transferring the diesel fuel from the pump to the container. Hold the hose nozzle firmly against the side of the container while filling it. This prevents static electricity buildup which could cause sparks and ignite fuel vapors.
- **NEVER** place diesel fuel or other flammable material such as oil, hay or dried grass close to the engine during engine operation or shortly after shut down.
- Failure to comply will result in death or serious injury.

0000014en

⚠ DANGER**FIRE AND EXPLOSION HAZARD!**

- Diesel fuel is flammable and explosive under certain conditions.
- Before you operate the engine, check for fuel leaks. Replace rubberized fuel hoses every two years or every 2000 hours of engine operation, whichever comes first, even if the engine has been out of service. Rubberized fuel lines tend to dry out and become brittle after two years or 2000 hours of engine operation, whichever comes first.
- Failure to comply will result in death or serious injury.

0000015en

CAUTION

- Only use diesel fuels recommended by Yanmar for the best engine performance, to prevent engine damage and to comply with EPA warranty requirements.
- Only use clean diesel fuel.
- **NEVER** remove primary strainer from the fuel tank filler port. If removed, dirt and debris could get into the fuel system causing it to clog.

0000004enMarine

BEFORE YOU OPERATE

To fill the fuel tank:

1. Clean the area around the fuel cap.
2. Remove the fuel cap from the fuel tank.
3. Stop fueling when the gauge shows the fuel tank is full. NEVER overfill the fuel tank.
4. Replace the fuel cap and hand-tighten. Over-tightening the fuel cap will damage it.

Bleeding the Fuel System

The fuel system needs to be bled under the following conditions:

- Before starting the engine for the first time.
- After running out of fuel and fuel has been added to the fuel tank.
- After fuel system maintenance such as changing the fuel filter and draining the fuel filter / water separator, or replacing a fuel system component.

⚠ DANGER



FIRE AND EXPLOSION HAZARD!

- Diesel fuel is extremely flammable and explosive under certain conditions.
- When you prime the fuel system, operate the fuel priming lever of the mechanical fuel pump several times until the fuel filter cup is filled with fuel.
- NEVER open the air vent valve while the fuel system is being primed. The fuel filter has an internal air bleed port.
- Failure to comply will result in death or serious injury.

0000016en

CAUTION



- ALWAYS be environmentally responsible.
- Follow the guidelines of the EPA or other governmental agencies for the proper disposal of hazardous materials such as engine oil, diesel fuel and engine coolant. Consult the local authorities or reclamation facility.
- NEVER dispose of hazardous materials irresponsibly by dumping them into a sewer, on the ground or into ground water or waterways.
- Failure to follow these procedures may seriously harm the environment.

0000013en

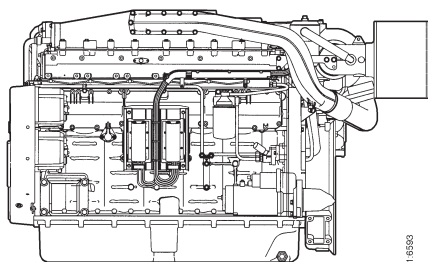

Figure 2

1. Install a transparent plastic hose on each fuel rail bleeder valve (**Figure 2, (1)**). Place the hoses in an appropriate container.
2. Open the bleeder valve and operate the hand pump (**Figure 2, (2)**) until fuel flows without air bubbles. This may take 130 - 150 pump strokes.
3. Close the bleeder valves and remove the hoses.
4. Continue hand pumping until there is resistance:
 - Approximately 20 strokes after replacing the fuel filter
 - Approximately 50 strokes after replacing a fuel injector
5. Start the engine and check for leaks.

CAUTION

NEVER hold the key in the START position for longer than 15 seconds or the starter motor will overheat.

000007en

If the engine fails to start after bleeding:

- Open the bleeder valves again and operate the hand pump until fuel without air bubbles flows out.
- Tighten the bleeder valves. Start the engine and check for leaks.

ENGINE OIL

CAUTION

- **Only use the engine oil specified. Other engine oils may affect warranty coverage, cause internal engine components to seize, or shorten engine life.**
- **Prevent dirt and debris from contaminating engine oil. Carefully clean the oil cap / dipstick and the surrounding area before you remove the cap.**
- **NEVER mix different types of engine oil. This may adversely affect the lubricating properties of the engine oil.**
- **NEVER overfill. Overfilling may result in white exhaust smoke, engine overspeed or internal damage.**

000005en

BEFORE YOU OPERATE

Engine Oil Specifications

Use an engine oil that meets or exceeds the following guidelines and classifications:

Service Categories

- API Service Categories CD or higher
- ACEA Service Categories E-3, E-4, and E-5
- JASO Service Category DH-1

Definitions

- API Classification (American Petroleum Institute)
- ACEA Classification (Association des Constructeurs Européens d'Automobilies)
- JASO (Japanese Automobile Standards Organization)

Notes:

1. Be sure the engine oil, engine oil storage containers, and engine oil filling equipment are free of sediments and water.
2. Change the engine oil after the first 50 hours of operation and then at every 250 hours thereafter.
3. Select the oil viscosity based on the ambient temperature where the engine is being operated. See the SAE Service Grade Viscosity Chart (**Figure 3**).
4. Yanmar does not recommend the use of engine oil "additives."

Additional Technical Engine Oil Requirements:

The engine oil must be changed when the Total Base Number (TBN) has been reduced to 2.0. TBN (mgKOH/g) test method; JIS K-201-5.2-2 (HCl), ASTM D4739 (HCl).

Engine Oil Viscosity

Select the appropriate engine oil viscosity based on the ambient temperature shown in the SAE Service Grade Viscosity Chart in (**Figure 3**).

SAE15W40 is the recommended oil viscosity.

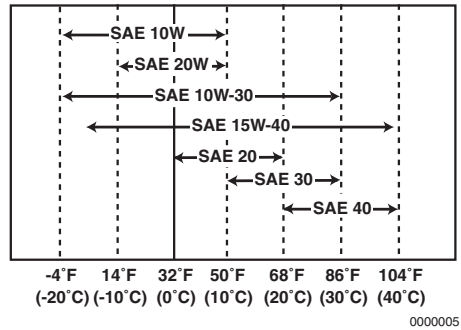

Figure 3

Maximum Angles of Inclination During Operation

Maximum permissible angles during operation vary, depending on the type of oil sump (**Figure 4**).

Note: The specified angle may only occur intermittently.

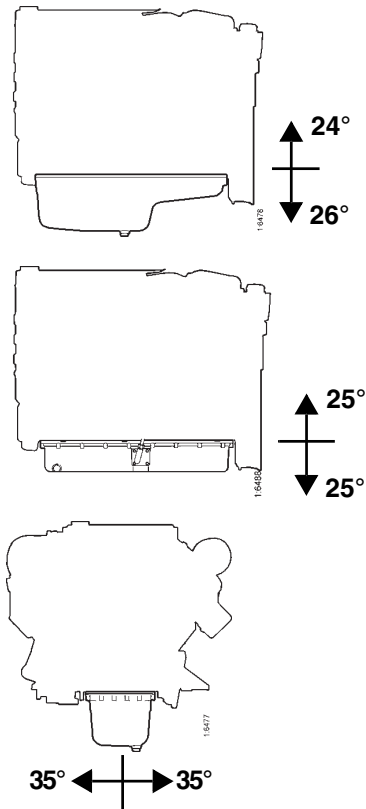

Figure 4

Checking Engine Oil

1. Make sure engine is level.
2. Remove dipstick (**Figure 5, (1)**) and wipe with clean cloth.
3. Fully reinsert dipstick.
4. Remove dipstick. The oil level should be between upper (**Figure 5, (2)**) and lower (**Figure 5, (3)**) lines on the dipstick.
5. Fully reinsert dipstick.



Figure 5

BEFORE YOU OPERATE

Adding Engine Oil

CAUTION

- **NEVER** overfill the engine with engine oil.
- **ALWAYS** keep the oil level between upper and lower lines on the oil cap / dipstick.

0000015en

1. Remove the oil fill port cap and fill with engine oil.
2. Fill with oil to the upper limit (**Figure 5, (2)**) on the dipstick (**Figure 5, (1)**). Insert the dipstick fully to check the level.
3. Tighten the fill port cap securely by hand.

Selection of Marine Gear Oil

Refer to the instruction book for each marine gear.

ENGINE COOLANT

DANGER



SCALD HAZARD!

- **NEVER** remove the coolant filler cap if the engine is hot. Steam and hot engine coolant will escape and seriously burn you. Allow the engine to cool sufficiently before attempting to remove the filler cap.
- **Securely tighten the filler cap after checking the coolant level. Steam can escape during engine operation if the cap is loose.**
- **Failure to comply will result in death or serious injury.**

0000002enMarine

CAUTION**COOLANT HAZARD!**

- Wear eye protection and rubber gloves when you handle Long Life engine coolant. If contact with the eyes or skin should occur, flush eyes and wash immediately with clean water.
- Failure to comply may result in minor or moderate injury.

0000005enMarine

CAUTION

- Only use the engine coolant specified. Other engine coolants may affect warranty coverage, cause an internal buildup of rust and scale and / or shorten engine life.
- Prevent dirt and debris from contaminating engine coolant. Carefully clean the heat exchanger cap and the surrounding area before you remove the cap.
- NEVER mix different types of engine coolants. This may adversely affect the properties of the engine coolant.

0000006enTrans

Engine Coolant Specifications

Use a Long Life Coolant (LLC) that meets or exceeds the following guidelines and specifications:

- ASTM D6210, D4985 (US)
- JIS K-2234 (Japan)
- SAE J814C, J1941, J1034 or J2036 (International)

Note: In the U.S., LLC is required for the warranty to be valid.

Coolant (Closed Cooling System)**IMPORTANT**

Always add LLC to soft water - especially when operating in cold weather. Without LLC, cooling performance will decrease due to scale and rust in the cooling system. Water alone may freeze and form ice; it expands approximately 9% in volume.

Use the proper amount of coolant concentrate for the ambient temperature as specified by the LLC manufacturer. LLC concentration should be a minimum of 30% to a maximum of 60%. Too much LLC will decrease the cooling efficiency also.

Do not mix different types or brands of LLC or a harmful sludge may form.

Do not use hard water. Water should be clean and free from sludge or particles.

BEFORE YOU OPERATE

Following the manufacturer's recommendations. Use a proper LLC which will not have any adverse effects on the materials (cast iron, aluminum, copper, etc.) of the engine's fresh water cooling system. See *Engine Coolant Specifications*.

Replace engine coolant periodically, according to the maintenance schedule in this *Operation Manual*.

Remove scale from the cooling system periodically by flushing the system.

Checking the Coolant Level

 **DANGER**



SCALD HAZARD!

- **NEVER** remove the coolant filler cap if the engine is hot. Steam and hot engine coolant will escape and seriously burn you. Allow the engine to cool sufficiently before attempting to remove the filler cap.
- **Securely** tighten the filler cap after checking the coolant level. Steam can escape during engine operation if the cap is loose.
- **Failure to comply will result in death or serious injury.**

000002enMarine

 **WARNING**



BURN HAZARD!

- **Wait** until the engine cools before you drain the engine coolant. Hot engine coolant may splash and burn you.
- **Failure to comply could result in death or serious injury.**

0000016en

⚠ CAUTION

<p>COOLANT HAZARD!</p> <ul style="list-style-type: none"> • Wear eye protection and rubber gloves when you handle Long Life engine coolant. If contact with the eyes or skin should occur, flush eyes and wash immediately with clean water. • Failure to comply may result in minor or moderate injury. <p style="text-align: right; font-size: small;">000005enMarine</p>

To Check the Coolant Level:

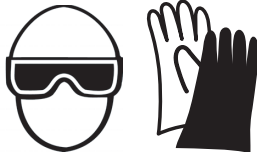
1. Open the coolant recovery tank fill cap and check the coolant level.
 - The correct level for a cold engine is approximately 50 mm (2.0 in.) below the full line.
2. Add coolant as necessary. Do not add water.

CAUTION

<p>COOLANT HAZARD!</p> <p>When adding large amounts of coolant, NEVER pour cold coolant into a hot engine. The cylinder block and cylinder head could crack.</p> <p style="text-align: right; font-size: small;">0000029</p>

CAUTION
<ul style="list-style-type: none"> • Only use the engine coolant specified. Other engine coolants may affect warranty coverage, cause an internal buildup of rust and scale and / or shorten engine life. • Prevent dirt and debris from contaminating engine coolant. Carefully clean the heat exchanger cap and the surrounding area before you remove the cap. • NEVER mix different types of engine coolants. This may adversely affect the properties of the engine coolant. <p style="text-align: right; font-size: small;">000006enTrans</p>

BEFORE YOU OPERATE

DAILY CHECKS

Before you head out for the day, make sure the Yanmar engine is in good operating condition. Make sure you check the following items.

WARNING



HIGH PRESSURE HAZARD!

- **Avoid skin contact with high pressure diesel fuel spray caused by a fuel system leak such as a broken fuel injection line. High pressure fuel can penetrate your skin and result in serious injury. If you are exposed to high pressure fuel spray, obtain prompt medical treatment.**
- **NEVER check for a fuel leak with your hands. ALWAYS use a piece of wood or cardboard. Have your authorized Yanmar marine dealer or distributor repair the damage.**
- **Failure to comply could result in death or serious injury.**

000008enMarine

CAUTION

It is important to perform daily checks as listed in the Operation Manual.

Periodic maintenance prevents unexpected downtime, reduces the number of accidents due to poor engine performance and helps extend the life of the engine.

0000060enMarine

Visual Checks

1. Check for engine oil leaks.
2. Check for fuel leaks.
3. Check for engine coolant leaks.
4. Check for damaged or missing parts.
5. Check for loose, missing, or damaged fasteners.
6. Check the electrical harnesses for cracks, abrasions, and damaged or corroded connectors.
7. Check hoses for cracks, abrasions, and damaged, loose or corroded clamps.
8. Check the fuel filter / water separator for presence of water and contaminants. If you find any water or contaminants, drain the fuel filter / water separator. *See Drain or Replace the Fuel Filter / Water Separator on page 91.* If you have to drain the fuel filter / water separator frequently, drain the fuel tank and check for the presence of water in your fuel supply. *See Drain the Fuel Tank on page 93.*

CAUTION

If any problem is noted during the visual check, the necessary corrective action should be taken before you operate the engine.

0000021en

Preparing Fuel, Oil and Coolant in Reserve

Prepare sufficient fuel for the day's operation. Always store engine oil and coolant in reserve (for at least one refill) on board, to be ready for emergencies.

Check Diesel Fuel, Engine Oil, and Engine Coolant Levels

Follow the procedures in *Filling the Fuel Tank on page 34*, *Checking Engine Oil on page 39* and *Check Diesel Fuel, Engine Oil, and Engine Coolant Levels on page 45* to check these levels.

Checking and Refilling Marine Gear Oil

Refer to the operation manual for the marine gear.

Checking the Battery Electrolyte Level

Be sure to check the battery electrolyte level before use. See *Check the Battery Electrolyte Level (Servicable Batteries Only) on page 91*.

Checking the Alternator Belt

Be sure to check the belt tension before use. See *Check and Adjust the Alternator Belt on page 86*.

Checking the Alarm Indicators

Check the instruments and alarm indicators at regular intervals.

This Page Intentionally Left Blank

ENGINE OPERATION

This section of the *Operation Manual* describes the procedures for starting the engine, checking engine performance during operation, and shutting the engine down.

CAUTION



NEVER permit anyone to install or operate the engine without proper training.

- **Read and understand this Operation Manual before you operate or service the engine to ensure that you follow safe operating practices and maintenance procedures.**
- **Safety signs and labels are additional reminders for safe operating and maintenance techniques.**
- **See your authorized Yanmar marine dealer or distributor for additional training.**

0000002enMarine

DANGER



SCALD HAZARD!

- **NEVER** remove the coolant filler cap if the engine is hot. Steam and hot engine coolant will escape and seriously burn you. Allow the engine to cool sufficiently before attempting to remove the filler cap.
- Securely tighten the filler cap after checking the coolant level. Steam can escape during engine operation if the cap is loose.
- Failure to comply will result in death or serious injury.

000002enMarine

DANGER



EXPLOSION HAZARD!

- Keep the area around the battery well-ventilated. While the engine is running or the battery is charging, hydrogen gas is produced which can be easily ignited.
- Keep sparks, open flame and any other form of ignition away while the engine is running or battery is charging.
- Failure to comply will result in death or serious injury.

000003en

DANGER



FIRE AND EXPLOSION HAZARD!

- Only use the key switch to start the engine.
- **NEVER** jump start the engine. Sparks caused by shorting the battery to the starter terminals may cause a fire or explosion.
- Failure to comply will result in death or serious injury.

000004en

! DANGER**FIRE AND EXPLOSION HAZARD!**

- Diesel fuel is flammable and explosive under certain conditions.
- Only fill the fuel tank with diesel fuel. Filling the fuel tank with gasoline may result in a fire and will damage the engine.
- NEVER refuel with the engine running.
- Wipe up all spills immediately.
- Keep sparks, open flames or any other form of ignition (match, cigarette, static electric source) well away when refueling.
- NEVER overfill the fuel tank.
- Fill the fuel tank. Store any containers containing fuel in a well-ventilated area, away from any combustibles or sources of ignition.
- Failure to comply will result in death or serious injury.

000005en

! DANGER**FIRE AND EXPLOSION HAZARD!**

- Diesel fuel is flammable and explosive under certain conditions.
- NEVER remove the fuel cap with the engine running.
- Failure to comply will result in death or serious injury.

0000011en

DANGER



FIRE AND EXPLOSION HAZARD!

- Diesel fuel is extremely flammable and explosive under certain conditions.
- Be sure to place the diesel fuel container on the ground when transferring the diesel fuel from the pump to the container. Hold the hose nozzle firmly against the side of the container while filling it. This prevents static electricity buildup which could cause sparks and ignite fuel vapors.
- NEVER place diesel fuel or other flammable material such as oil, hay or dried grass close to the engine during engine operation or shortly after shut down.
- Failure to comply will result in death or serious injury.

0000014en

DANGER



FIRE AND EXPLOSION HAZARD!

- Diesel fuel is flammable and explosive under certain conditions.
- Before you operate the engine, check for fuel leaks. Replace rubberized fuel hoses every two years or every 2000 hours of engine operation, whichever comes first, even if the engine has been out of service. Rubberized fuel lines tend to dry out and become brittle after two years or 2000 hours of engine operation, whichever comes first.
- Failure to comply will result in death or serious injury.

0000015en

WARNING

SUDDEN MOVEMENT HAZARD!

- Be sure the boat is in open water away from other boats, docks, and other obstructions before increasing rpm.
- Failure to comply could result in death or serious injury.

0000006enMarine

⚠ WARNING**SEVER HAZARD!**

- Keep hands and other body parts away from moving / rotating parts such as the flywheel or PTO shaft.
- Wear tight fitting clothing and keep your hair short or tie it back while the engine is running.
- Remove all jewelry before you operate or service the engine.
- NEVER start the engine in gear. Sudden movement of the engine and / or vessel could cause death or serious personal injury.
- NEVER operate the engine without the guards in place.
- Before you start the engine make sure that all bystanders are clear of the area.
- Keep children and pets away while the engine is operating.
- Check before starting the engine that any tools or shop rags used during maintenance have been removed from the area.
- Failure to comply could result in death or serious injury.

000002enMarine

⚠ WARNING**EXHAUST HAZARD!**

- NEVER operate the engine in an enclosed area such as a garage, tunnel, underground room, manhole or ship's hold without proper ventilation.
- NEVER block windows, vents, or other means of ventilation if the engine is operating in an enclosed area. All internal combustion engines create carbon monoxide gas during operation. Accumulation of this gas within an enclosure could cause illness or even death.
- Make sure that all connections are tightened to specifications after repair is made to the exhaust system.
- Failure to comply could result in death or serious injury.

000003en

WARNING



ALCOHOL AND DRUG HAZARD!

- **NEVER** operate the engine while you are under the influence of alcohol or drugs.
- **NEVER** operate the engine when you are feeling ill.
- Failure to comply could result in death or serious injury.

000004en

WARNING



EXPOSURE HAZARD!

- Wear personal protective equipment such as gloves, work shoes, eye and hearing protection as required by the task at hand.
- **NEVER** wear jewelry, unbuttoned cuffs, ties or loose fitting clothing when you are working near moving / rotating parts such as the cooling fan, flywheel or PTO shaft.
- **ALWAYS** tie back long hair when you are working near moving / rotating parts such as a cooling fan, flywheel, or PTO shaft.
- **NEVER** operate the engine while wearing a headset to listen to music or radio because it will be difficult to hear the alert signals.
- Failure to comply could result in death or serious injury.

000005en

⚠ WARNING**HIGH PRESSURE HAZARD!**

- Avoid skin contact with high pressure diesel fuel spray caused by a fuel system leak such as a broken fuel injection line. High pressure fuel can penetrate your skin and result in serious injury. If you are exposed to high pressure fuel spray, obtain prompt medical treatment.
- NEVER check for a fuel leak with your hands. ALWAYS use a piece of wood or cardboard. Have your authorized Yanmar marine dealer or distributor repair the damage.
- Failure to comply could result in death or serious injury.

0000008enMarine

⚠ WARNING**BURN HAZARD!**

- If you must drain the engine oil while it is still hot, stay clear of the hot engine oil to avoid being burned.
- ALWAYS wear eye protection.
- Failure to comply could result in death or serious injury.

0000011en

⚠ WARNING**BURN HAZARD!**

- Keep your hands, and other body parts, away from hot engine surfaces such as the muffler, exhaust pipe, turbocharger (if equipped) and engine block during operation and shortly after you shut the engine down. These surfaces are extremely hot while the engine is operating and could seriously burn you.
- Failure to comply could result in death or serious injury.

0000015en

WARNING



BURN HAZARD!

- Wait until the engine cools before draining seawater from the cooling system. Hot seawater may splash and burn you.
- Failure to comply could result in death or serious injury.

0000016enMarine

CAUTION

Observe the following environmental operating conditions to maintain engine performance and avoid premature engine wear:

- Avoid operating in extremely dusty conditions.
- Avoid operating in the presence of chemical gases or fumes.

0000003enMarine

CAUTION

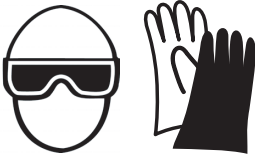

COOLANT HAZARD!

- Wear eye protection and rubber gloves when you handle Long Life engine coolant. If contact with the eyes or skin should occur, flush eyes and wash immediately with clean water.
- Failure to comply may result in minor or moderate injury.

0000005enMarine

CAUTION

- Only use diesel fuels recommended by Yanmar for the best engine performance, to prevent engine damage and to comply with EPA warranty requirements.
- Only use clean diesel fuel.
- NEVER remove primary strainer from the fuel tank filler port. If removed, dirt and debris could get into the fuel system causing it to clog.

0000004enMarine

CAUTION

- Only use the engine oil specified. Other engine oils may affect warranty coverage, cause internal engine components to seize, or shorten engine life.
- Prevent dirt and debris from contaminating engine oil. Carefully clean the oil cap / dipstick and the surrounding area before you remove the cap.
- NEVER mix different types of engine oil. This may adversely affect the lubricating properties of the engine oil.
- NEVER overfill. Overfilling may result in white exhaust smoke, engine overspeed or internal damage.

000005en

CAUTION

NEVER hold the key in the START position for longer than 15 seconds or the starter motor will overheat.

000007en

CAUTION

NEVER use an engine starting aid such as ether. Engine damage will result.

000009en

CAUTION

- Only use the engine coolant specified. Other engine coolants may affect warranty coverage, cause an internal buildup of rust and scale and / or shorten engine life.
- Prevent dirt and debris from contaminating engine coolant. Carefully clean the heat exchanger cap and the surrounding area before you remove the cap.
- NEVER mix different types of engine coolants. This may adversely affect the properties of the engine coolant.

000006enTrans

CAUTION

If any problem is noted during the visual check, the necessary corrective action should be taken before you operate the engine.

0000021en

CAUTION

If any indicator illuminates during engine operation, stop the engine immediately. Determine the cause and repair the problem before you continue to operate the engine.

0000029en

CAUTION

Observe the following environmental operating conditions to maintain engine performance and avoid premature engine wear:

- **NEVER** run the engine if the ambient temperature is above +40°C (+104°F) or below -16°C (+5°F)
 - ◆ If the ambient temperature exceeds +40°C (+104°F) the engine may overheat and cause the engine oil to break down.
 - ◆ If the ambient temperature falls below -16°C (+5°F) rubber components such as gaskets and seals will harden causing premature engine wear and damage.
 - ◆ See your authorized Yanmar marine engine dealer or distributor if the engine will be operated in either temperature extreme.
- See your authorized Yanmar marine dealer or distributor if you need to operate the engine at high altitudes. At high altitudes the engine will lose power, run rough, and produce exhaust gases that exceed the design specifications.

0000065enMarine

CAUTION

Clean or replace the air cleaner element if the air intake restriction exceeds the value listed in the Operation and Service Manuals.

0000046enMarine

CAUTION

NEVER turn off the battery switch (if equipped) or short the battery cables during operation. Damage to the electric system will result.

0000061en

CAUTION

Be sure to close the seacock. Neglecting to close the seacock could allow water to leak into the boat and may cause it to sink.

0000152en

STARTING ENGINE

To start the engine:

1. Open the seacock (if equipped).
2. Open the fuel tank cock.
3. Put transmission in neutral.
4. Turn the battery master switch (if equipped) ON.
5. Press the ENG ON switch (if equipped) or turn key switch ON.

Starting at Low Temperatures

CAUTION

NEVER hold the key in the START position for longer than 15 seconds or the starter motor will overheat.

000007en

Comply with local environmental requirements. Use engine heaters to avoid starting problems and white smoke.

To limit white smoke, run the engine at low speed and under moderate load until the engine reaches normal operating temperature. A light load on a cold engine provides better combustion and faster engine warm-up than no load.

Avoid running the engine at idling speed any longer than necessary.

CAUTION

NEVER use an engine starting aid such as ether. Engine damage will result.

000009en

SHUTTING DOWN THE ENGINE

CAUTION

For maximum engine life, Yanmar recommends that when shutting the engine down, you allow the engine to run, without load, for five minutes. This will allow the engine components that operate at high temperatures, such as the exhaust system, to cool slightly before the engine itself is shut down.

000008enYDG

1. Check to see that there are no active faults.
2. Push the OFF switch (if equipped) or turn the key switch to OFF. Use the emergency stop switch (if equipped) only in an emergency.
3. Turn the battery master switch (if equipped) OFF.
4. Close the fuel tank cock.
5. Close the seacock (if equipped).

CAUTION

Be sure to close the seacock. Neglecting to close the seacock could allow water to leak into the boat and may cause it to sink.

0000152en

CHECKING THE ENGINE AFTER OPERATION

- Check that the key switch is in the OFF position and battery master switch (if equipped) is OFF.
- Fill the fuel tank. Make sure that the fill cap and the area around the fill opening are clean to avoid contamination of the fuel.
- Turn off the inlet valve (seacock) for the seawater system (if equipped).
- If there is a risk of freezing, check that the closed coolant system contains enough glycol. *See Engine Coolant Specifications on page 41.*
- If there is a risk of freezing, empty the seawater system.
- At temperatures below 0°C (32°F), drain seawater system and connect the engine heater (if equipped).

PERIODIC MAINTENANCE

This section of the *Operation Manual* describes the procedures for proper care and maintenance of the engine.

SAFETY PRECAUTIONS

Before You Operate

CAUTION





NEVER permit anyone to install or operate the engine without proper training.



- **Read and understand this Operation Manual before you operate or service the engine to ensure that you follow safe operating practices and maintenance procedures.**
- **Safety signs and labels are additional reminders for safe operating and maintenance techniques.**
- **See your authorized Yanmar marine dealer or distributor for additional training.**

000002enMarine

PERIODIC MAINTENANCE

During Operation and Maintenance

	
	
EXPLOSION HAZARD!	
<ul style="list-style-type: none">• Keep the area around the battery well-ventilated. While the engine is running or the battery is charging, hydrogen gas is produced which can be easily ignited.• Keep sparks, open flame and any other form of ignition away while the engine is running or battery is charging.• Failure to comply will result in death or serious injury.	
0000003en	

	
	
SCALD HAZARD!	
<ul style="list-style-type: none">• NEVER remove the coolant filler cap if the engine is hot. Steam and hot engine coolant will escape and seriously burn you. Allow the engine to cool sufficiently before attempting to remove the filler cap.• Securely tighten the filler cap after checking the coolant level. Steam can escape during engine operation if the cap is loose.• Failure to comply will result in death or serious injury.	
0000002enMarine	

⚠ DANGER



FIRE AND EXPLOSION HAZARD!

- Diesel fuel is flammable and explosive under certain conditions.
- When you remove any fuel system component to perform maintenance (such as changing the fuel filter) place an approved container under the opening to catch the fuel.
- NEVER use a shop rag to catch the fuel. Vapors from the rag are flammable and explosive.
- Wipe up any spills immediately.
- Wear eye protection. The fuel system is under pressure and fuel could spray out when you remove any fuel system component.
- Failure to comply will result in death or serious injury.

000009en

⚠ DANGER



FIRE AND EXPLOSION HAZARD!

- Diesel fuel is flammable and explosive under certain conditions.
- NEVER use diesel fuel as a cleaning agent.
- Failure to comply will result in death or serious injury.

000012en

⚠ DANGER



FIRE AND EXPLOSION HAZARD!

- Diesel fuel is flammable and explosive under certain conditions.
- NEVER remove the fuel cap with the engine running.
- Failure to comply will result in death or serious injury.

000011en

DANGER



FIRE AND EXPLOSION HAZARD!

- Only use the key switch to start the engine.
- NEVER jump start the engine. Sparks caused by shorting the battery to the starter terminals may cause a fire or explosion.
- Failure to comply will result in death or serious injury.

000004en

DANGER



CRUSH HAZARD!

- When you need to transport an engine for repair have a helper assist you attach it to a hoist and load it on a truck.
- NEVER stand under hoisted engine. If the hoist mechanism fails, the engine will fall on you, causing serious injury or death.
- Failure to comply will result in death or serious injury.

000008en

DANGER



FIRE AND EXPLOSION HAZARD!

- Diesel fuel is flammable and explosive under certain conditions.
- Only fill the fuel tank with diesel fuel. Filling the fuel tank with gasoline may result in a fire and will damage the engine.
- NEVER refuel with the engine running.
- Wipe up all spills immediately.
- Keep sparks, open flames or any other form of ignition (match, cigarette, static electric source) well away when refueling.
- NEVER overfill the fuel tank.
- Fill the fuel tank. Store any containers containing fuel in a well-ventilated area, away from any combustibles or sources of ignition.
- Failure to comply will result in death or serious injury.

000005en

⚠ DANGER



FIRE AND EXPLOSION HAZARD!

- Diesel fuel is flammable and explosive under certain conditions.
- Before you operate the engine, check for fuel leaks. Replace rubberized fuel hoses every two years or every 2000 hours of engine operation, whichever comes first, even if the engine has been out of service. Rubberized fuel lines tend to dry out and become brittle after two years or 2000 hours of engine operation, whichever comes first.
- Failure to comply will result in death or serious injury.

0000015en

⚠ DANGER



EXPLOSION HAZARD!

- NEVER check the remaining battery charge by shorting out the terminals. This will result in a spark and may cause an explosion or fire. Use a hydrometer to check the remaining battery charge.
- If the electrolyte is frozen, slowly warm the battery before you recharge it.
- Failure to comply will result in death or serious injury.

0000007en

DANGER



FIRE AND EXPLOSION HAZARD!

- Diesel fuel is flammable and explosive under certain conditions.
- If the unit has an electric fuel pump, when you prime the fuel system, turn the key switch to the ON position for 10 to 15 seconds to allow the electric fuel pump to prime the system.
- If the unit has a mechanical fuel pump, when you prime the fuel system, operate the fuel priming lever of the mechanical fuel pump several times until the fuel filter cup is filled with fuel.
- NEVER open the air vent valve while the fuel system is being primed. The fuel filter has an internal air bleed port.
- Failure to comply will result in death or serious injury.

0000010en

DANGER

NEVER start the engine unless the air filter is installed.

Failure to comply will result in death or serious injury.

0000025en

WARNING



SEVER HAZARD!

- Keep hands and other body parts away from moving / rotating parts such as the flywheel or PTO shaft.
- Wear tight fitting clothing and keep your hair short or tie it back while the engine is running.
- Remove all jewelry before you operate or service the engine.
- NEVER start the engine in gear. Sudden movement of the engine and / or vessel could cause death or serious personal injury.
- NEVER operate the engine without the guards in place.
- Before you start the engine make sure that all bystanders are clear of the area.
- Keep children and pets away while the engine is operating.
- Check before starting the engine that any tools or shop rags used during maintenance have been removed from the area.
- Failure to comply could result in death or serious injury.

0000002enMarine

⚠ WARNING



EXHAUST HAZARD!

- NEVER operate the engine in an enclosed area such as a garage, tunnel, underground room, manhole or ship's hold without proper ventilation.
- NEVER block windows, vents, or other means of ventilation if the engine is operating in an enclosed area. All internal combustion engines create carbon monoxide gas during operation. Accumulation of this gas within an enclosure could cause illness or even death.
- Make sure that all connections are tightened to specifications after repair is made to the exhaust system.
- Failure to comply could result in death or serious injury.

000003en

⚠ WARNING



ALCOHOL AND DRUG HAZARD!

- NEVER operate the engine while you are under the influence of alcohol or drugs.
- NEVER operate the engine when you are feeling ill.
- Failure to comply could result in death or serious injury.

000004en

⚠ WARNING



BURN HAZARD!

- Batteries contain sulfuric acid. NEVER allow battery fluid to come in contact with clothing, skin or eyes. Severe burns could result. ALWAYS wear safety goggles and protective clothing when servicing the battery. If battery fluid contacts the eyes and / or skin, immediately flush the affected area with a large amount of clean water and obtain prompt medical treatment.
- Failure to comply could result in death or serious injury.

000007en

WARNING



EXPOSURE HAZARD!

- Wear personal protective equipment such as gloves, work shoes, eye and hearing protection as required by the task at hand.
- NEVER wear jewelry, unbuttoned cuffs, ties or loose fitting clothing when you are working near moving / rotating parts such as the cooling fan, flywheel or PTO shaft.
- ALWAYS tie back long hair when you are working near moving / rotating parts such as a cooling fan, flywheel, or PTO shaft.
- NEVER operate the engine while wearing a headset to listen to music or radio because it will be difficult to hear the alert signals.
- Failure to comply could result in death or serious injury.

0000005en

WARNING

SUDDEN MOVEMENT HAZARD!

- Be sure the boat is in open water away from other boats, docks, and other obstructions before increasing rpm.
- Failure to comply could result in death or serious injury.

0000006enMarine

WARNING



HIGH PRESSURE HAZARD!

- Avoid skin contact with high pressure diesel fuel spray caused by a fuel system leak such as a broken fuel injection line. High pressure fuel can penetrate your skin and result in serious injury. If you are exposed to high pressure fuel spray, obtain prompt medical treatment.
- NEVER check for a fuel leak with your hands. ALWAYS use a piece of wood or cardboard. Have your authorized Yanmar marine dealer or distributor repair the damage.
- Failure to comply could result in death or serious injury.

0000008enMarine

⚠ WARNING



SHOCK HAZARD!

- Turn off the battery switch (if equipped) or disconnect the negative battery cable before servicing the electrical system.
- Check the electrical harnesses for cracks, abrasions, and damaged or corroded connectors. ALWAYS keep the connectors and terminals clean.
- Failure to comply could result in death or serious injury.

000009en

⚠ WARNING



ENTANGLEMENT HAZARD!

- Stop the engine before you begin to service it.
- NEVER leave the key in the key switch when you are servicing the engine. Someone may accidentally start the engine and not realize you are servicing it. This could result in a serious injury.
- If you must service the engine while it is operating, remove all jewelry, tie back long hair, and keep your hands, other body parts and clothing away from moving / rotating parts.
- Failure to comply could result in death or serious injury.

0000010en

⚠ WARNING



BURN HAZARD!

- Wait until the engine cools before you drain the engine coolant. Hot engine coolant may splash and burn you.
- Failure to comply could result in death or serious injury.

0000016en

WARNING



BURN HAZARD!

- If you must drain the engine oil while it is still hot, stay clear of the hot engine oil to avoid being burned.
- **ALWAYS** wear eye protection.
- Failure to comply could result in death or serious injury.

0000011en

WARNING



BURN HAZARD!

- Wait until the engine cools before draining seawater from the cooling system. Hot seawater may splash and burn you.
- Failure to comply could result in death or serious injury.

0000016enMarine

WARNING



BURN HAZARD!

- Keep your hands, and other body parts, away from hot engine surfaces such as the muffler, exhaust pipe, turbocharger (if equipped) and engine block during operation and shortly after you shut the engine down. These surfaces are extremely hot while the engine is operating and could seriously burn you.
- Failure to comply could result in death or serious injury.

0000015en

WARNING



FIRE HAZARD!

- Undersized wiring systems can cause an electrical fire.
- Failure to comply could result in death or serious injury.

0000027en

⚠ CAUTION



COOLANT HAZARD!

- Wear eye protection and rubber gloves when you handle Long Life engine coolant. If contact with the eyes or skin should occur, flush eyes and wash immediately with clean water.
- Failure to comply may result in minor or moderate injury.

000005enMarine

CAUTION

- Only use diesel fuels recommended by Yanmar for the best engine performance, to prevent engine damage and to comply with EPA warranty requirements.
- Only use clean diesel fuel.
- NEVER remove primary strainer from the fuel tank filler port. If removed, dirt and debris could get into the fuel system causing it to clog.

000004enMarine

⚠ CAUTION



FLYING OBJECT HAZARD!

- ALWAYS wear eye protection when servicing engine and when using compressed air or high-pressure water. Dust, flying debris, compressed air, pressurized water or steam may injure your eyes.
- Failure to comply may result in minor or moderate injury.

000003en

CAUTION

NEVER attempt to adjust the low or high idle speed limit screw. This may impair the safety and performance of the engine and shorten its life. If adjustment is ever required, see your authorized Yanmar marine dealer or distributor.

000045enMarine

CAUTION

If any problem is noted during the visual check, the necessary corrective action should be taken before you operate the engine.

0000021en

CAUTION

Be sure to close the seacock.

Neglecting to close the seacock could allow water to leak into the boat and may cause it to sink.

0000152en

CAUTION

- If the vessel is equipped with a water lift (water lock) muffler, excessive cranking could cause seawater to enter the cylinders and damage the engine. If the engine does not start after cranking 15 seconds, close the thru-hull water intake valve to avoid filling the muffler with water. Crank for 15 seconds or until the engine starts. When the engine does start, stop the engine immediately and press the switch to the OFF position.
- Be sure to re-open the seacock and restart the engine. Operate the engine normally.

0000151en

CAUTION

Observe the following environmental operating conditions to maintain engine performance and avoid premature engine wear:

- NEVER run the engine if the ambient temperature is above +40°C (+104°F) or below -16°C (+5°F)
 - ◆ If the ambient temperature exceeds +40°C (+104°F) the engine may overheat and cause the engine oil to break down.
 - ◆ If the ambient temperature falls below -16°C (+5°F) rubber components such as gaskets and seals will harden causing premature engine wear and damage.
 - ◆ See your authorized Yanmar marine engine dealer or distributor if the engine will be operated in either temperature extreme.
- See your authorized Yanmar marine dealer or distributor if you need to operate the engine at high altitudes. At high altitudes the engine will lose power, run rough, and produce exhaust gases that exceed the design specifications.

0000065enMarine

CAUTION

- Only use the engine coolant specified. Other engine coolants may affect warranty coverage, cause an internal buildup of rust and scale and / or shorten engine life.
- Prevent dirt and debris from contaminating engine coolant. Carefully clean the heat exchanger cap and the surrounding area before you remove the cap.
- NEVER mix different types of engine coolants. This may adversely affect the properties of the engine coolant.

000006enTrans

CAUTION

- NEVER overfill the engine with engine oil.
- ALWAYS keep the oil level between upper and lower lines on the oil cap / dipstick.

0000015en

CAUTION

For maximum engine life, Yanmar recommends that when shutting the engine down, you allow the engine to run, without load, for five minutes. This will allow the engine components that operate at high temperatures, such as the exhaust system, to cool slightly before the engine itself is shut down.

000008enYDG

CAUTION

- Only use the engine oil specified. Other engine oils may affect warranty coverage, cause internal engine components to seize, or shorten engine life.
- Prevent dirt and debris from contaminating engine oil. Carefully clean the oil cap / dipstick and the surrounding area before you remove the cap.
- NEVER mix different types of engine oil. This may adversely affect the lubricating properties of the engine oil.
- NEVER overfill. Overfilling may result in white exhaust smoke, engine overspeed or internal damage.

000005en

CAUTION

NEVER use an engine starting aid such as ether. Engine damage will result.

000009en

CAUTION

NEVER clean the coolant system with caustic soda. The aluminum parts may be damaged.

0000175en

CAUTION

Make sure the engine is installed on a level surface. If a Yanmar Marine Engine is installed at an angle that exceeds the specifications stated in the Yanmar Marine Installation manuals, engine oil may enter the combustion chamber causing excessive engine speed, white exhaust smoke and serious engine damage. This applies to engines that run continuously or those that run for short periods of time.

0000010enMarine

CAUTION

New Engine Break In:

- On the initial engine start-up, check for proper engine oil pressure, diesel fuel leaks, engine oil leaks, coolant leaks, and for proper operation of the indicators and / or gauges.
- During the first 50 hours of operation operate your new engine under a substantial load at all times. For best break-in results operate the engine at various speeds.
- Operating the engine in NEUTRAL must be avoided. During the first 50 hours, avoid operation below 2000 rpm.
- During the break-in period, carefully observe the engine oil pressure and engine temperature.
- During the break-in period, check the engine oil and coolant levels frequently.

0000011enMarine

CAUTION

Be careful not to get any oil on the belt(s). Oil on the belt causes slipping and stretching. Replace the belt if it is damaged.

0000153enMarine

CAUTION

If seawater is left inside of the engine, it may freeze and damage parts of the cooling system when the ambient temperature is below 0°C (32°F).

0000154en

CAUTION

Protect the air cleaner, turbocharger (if equipped) and electric components from damage when you use steam or high-pressure water to clean the engine.

0000014en

CAUTION

NEVER allow engine oil or diesel fuel oil to contact the flexible rubber mount. Oil makes rubber deteriorate.

0000155en

CAUTION

Establish a periodic maintenance plan according to the engine application and make sure you perform the required periodic maintenance at intervals indicated. Failure to follow these guidelines will impair the engine's safety and performance characteristics, shorten the engine's life and may affect the warranty coverage on your engine.

0000024en

CAUTION

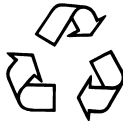

- **ALWAYS** be environmentally responsible.
- Follow the guidelines of the EPA or other governmental agencies for the proper disposal of hazardous materials such as engine oil, diesel fuel and engine coolant. Consult the local authorities or reclamation facility.
- **NEVER** dispose of hazardous materials irresponsibly by dumping them into a sewer, on the ground or into ground water or waterways.
- Failure to follow these procedures may seriously harm the environment.

0000013en

CAUTION

It is important to perform daily checks as listed in the Operation Manual.

Periodic maintenance prevents unexpected downtime, reduces the number of accidents due to poor engine performance and helps extend the life of the engine.

0000060enMarine

CAUTION

If the fuel filter / water separator is positioned higher than the fuel level in the fuel tank, water may not drip out when the fuel filter / water separator drain cock is opened. If this happens, turn the air vent screw on the top of the fuel filter / water separator 2-3 turns counterclockwise.

Be sure to tighten the air vent screw after the water has drained out.

0000025en

CAUTION

NEVER turn off the battery switch (if equipped) or short the battery cables during operation. Damage to the electric system will result.

0000061en

PRECAUTIONS

The Importance of Periodic Maintenance

Engine deterioration and wear occur in proportion to the length of time the engine has been in service and the conditions the engine is subjected to during operation. Periodic maintenance prevents unexpected downtime, reduces the number of accidents due to poor machine performance and helps extend the life of the engine.

CAUTION

- When the engine is operated in dusty conditions, clean the air cleaner element more frequently.
- **NEVER** operate the engine with the air cleaner or element(s) removed. This may allow foreign material to enter the engine and damage it.

0000026en

CAUTION

Clean or replace the air cleaner element if the air intake restriction exceeds the value listed in the Operation and Service Manuals.

0000046enMarine

Performing Periodic Maintenance

⚠ WARNING



EXHAUST HAZARD!

- **NEVER** operate the engine in an enclosed area such as a garage, tunnel, underground room, manhole or ship's hold without proper ventilation.
- **NEVER** block windows, vents, or other means of ventilation if the engine is operating in an enclosed area. All internal combustion engines create carbon monoxide gas during operation. Accumulation of this gas within an enclosure could cause illness or even death.
- **Make sure that all connections are tightened to specifications after repair is made to the exhaust system.**
- **Failure to comply could result in death or serious injury.**

000003en

Perform periodic maintenance procedures in an open, level area free from traffic. If possible, perform the procedures indoors to prevent environmental conditions such as rain, wind, or snow, from damaging the engine.

The Importance of Daily Checks

Periodic Maintenance Schedules assume that the daily checks are performed on a regular basis. Make it a habit of performing daily checks before the start of each operating day. See *Daily Checks* on page 44.

Keep a Log of Engine Hours and Daily Checks

Keep a log of the number of hours the engine is run each day and a log of the daily checks performed. Also note the date, type of repair (e.g., replaced alternator), and parts used for any service needed between the periodic maintenance intervals. Periodic maintenance intervals are every 50, 250, 500, 750, 1000 and 2000 engine hours. Failure to perform periodic maintenance will shorten the life of the engine.

Yanmar Replacement Parts

Yanmar recommends that you use genuine Yanmar parts when replacement parts are needed. Genuine replacement parts help ensure long engine life.

Tools Required

Before you start any periodic maintenance procedure make sure you have the tools you need to perform all of the required tasks.

Ask Your Authorized Yanmar Marine Dealer or Distributor For Help

Our professional service technicians have the expertise and skills to help you with any maintenance or service related procedures.

PERIODIC MAINTENANCE

Required EPA Maintenance USA Only

To maintain optimum engine performance and compliance with the Environmental Protection Agency (EPA) Regulations Engines, it is essential that you follow the *Periodic Maintenance Schedule on page 78* and *Periodic Maintenance Procedures* which start on page 81.

EPA Requirements USA Only

The following are the installation requirements for the EPA. Unless these requirements are met, the exhaust gas emissions will not be within the limits specified by the EPA.

Maximum exhaust gas restriction shall be 5.88 kPa; 600 mmAq (0.85 psi) or less.

Maximum air intake restriction shall be 6.23 kPa; 635 mmAq (0.90 psi) or less. Clean or replace the air cleaner element if the air intake restriction exceeds the above mentioned value.

EPA REQUIREMENTS

The EPA emission regulation is applicable only in USA.

Conditions to Ensure Compliance with EPA Emission Standards

This product is an EPA-approved engine.

The following are the conditions that must be met in order to ensure that the emissions during operation meet the EPA standards. Be sure to follow these:

The operating conditions should be as follows:

- Ambient temperature: -20° - 40°C (-4° - 104°F)
- Relative humidity: 80% or lower
- Permissible value for intake negative pressure: 3.9 kPa (400 mmAq) or lower
- Permissible value for exhaust back pressure: 19.6 kPa (2000 mmAq) or lower

The fuel and lubricating oil used should be as follows:

- Diesel fuel oil: ASTM D975 No. 1-D or No. 2-D, or equivalent (minimum of cetane No. 45)
- Lubricating oil: Type API, Class CD

Be sure to perform inspections as outlined in *Periodic Maintenance Procedures on page 81* and keep a record of the results.

Pay particular attention to these important points:

- Replacing the engine oil
- Replacing the lube oil filter
- Replacing the fuel filter
- Cleaning the intake silencer (air cleaner)

Note: Inspections are divided into two sections in accordance with who is responsible for performing the inspection: the user or the maker.

Inspection and Maintenance

See *Inspection and Maintenance of EPA Emission-Related Parts* on page 80 for the EPA emission-related parts. Inspection and maintenance procedures not shown in the *Inspection and Maintenance of EPA Emission-Related Parts* section are covered in *Periodic Maintenance Schedule* on page 78.

This maintenance must be performed to keep the emission values of your engine in the standard values during the warranty period. The warranty period is determined by the age of the engine or the number of hours of operation.

Tightening Fasteners

Use the correct amount of torque when you tighten fasteners on the machine. Applying excessive torque may damage the fastener or component and not enough torque may cause a leak or component failure.

PERIODIC MAINTENANCE SCHEDULE

Daily and periodic maintenance is important to keep the engine in good operating condition. The following is a summary of maintenance items by periodic maintenance intervals. Periodic maintenance intervals vary depending on engine application, loads, diesel fuel and engine oil used and are hard to establish definitively. The following should be treated only as a general guideline.

CAUTION

Establish a periodic maintenance plan according to the engine application and make sure you perform the required periodic maintenance at intervals indicated. Failure to follow these guidelines will impair the engine's safety and performance characteristics, shorten the engine's life and may affect the warranty coverage on your engine.

See your authorized Yanmar marine dealer or distributor for assistance when checking items marked with a ●.

000024en6LY3

Engines with Low Operating Hours

Run the engine until it reaches operating temperature and then perform the following maintenance procedures:

- Check the engine oil level. *See Checking Engine Oil on page 39.*
- Check the coolant level. *See Checking the Coolant Level on page 42.*
- Check the low pressure indicator. *See Checking the Alarm Indicators on page 45.*
- Check the fuel level. *See Filling the Fuel Tank on page 34.*
- Checking the battery electrolyte level. *See Check the Battery Electrolyte Level (Servicable Batteries Only) on page 91.*
- Clean the battery. *See Clean the Battery on page 110.*
- Check for any leakage, rectify as necessary. *See Check for Leakage of Fuel, Engine Oil and Engine Coolant on page 108.*

PERIODIC MAINTENANCE

○: Check ◇: Replace ●: Contact your authorized Yanmar marine dealer or distributor

System	Item	Daily	Periodic Maintenance Interval				
			Every 50 hrs. or one month whichever comes first	Every 250 hrs. or one year whichever comes first	Every 500 hrs. or 2 years whichever comes first	Every 1000 hrs. or 4 years whichever comes first	Every 2000 hrs. or 8 years whichever comes first
Whole	Visual inspection of engine exterior	○					
Fuel System	Check the fuel leve, and refill	○					
	Drain the fuel tank			○			
	Drain the fuel filter and the fuel / water separator		○				
	Replace the fuel filter element			◇			
	Check the unit injector rocker arms			● ¹ (1st time)		● ¹	
	Check the unit injector spray pattern			● ¹ (1st time)		● ¹	
	Overhaul and check fuel feed pump						●
	Replace rubber fuel hoses	Replace every 2 years or every 2000 hours, whichever comes first.					
Lubricating System	Check the engine oil level	Crankcase	○				
	Replace the engine oil	Crankcase		◇ (1st time)	◇		
	Replace the engine oil filter element			◇ (1st time)	◇		
	Clean engine oil cooler						●
Cooling System	Seawater outlet	○ During Operation					
	Check coolant level	○					
	Check the seawater pump impeller			○	◇		
	Replace the engine coolant	Every year When long life coolant is used, replace every two years. See Engine Coolant Specifications on page 41.					
	Clean and check the seawater passages					●	
	Clean seawater and engine cooling system						●
Air Intake and Exhaust System	Check or replace anodes			◇			
	Clean the air intake silencer			○			
	Clean the exhaust/water mixing elbow			○			
	Clean the turbocharger			● ¹			
	Flush charge air cooler			●			
Electrical System	Check the alarm indicators	○					
	Check the electrolyte level in the battery		○				
	Adjust / replace the tension of the alternator belt		○ (1st time)		○	◇	
	Check the wiring connectors			○			
Engine Cylinder Head and Block	Check for leakage of fuel, engine oil and engine coolant	○ After starting					
	Tighten all major nuts and bolts			●			
	Adjust intake / exhaust valve clearance			● (1st time)		●	

PERIODIC MAINTENANCE

O: Check ◇: Replace ●: Contact your authorized Yanmar marine dealer or distributor

System	Item	Daily	Periodic Maintenance Interval				
			Every 50 hrs. or one month whichever comes first	Every 250 hrs. or one year whichever comes first	Every 500 hrs. or 2 years whichever comes first	Every 1000 hrs. or 4 years whichever comes first	Every 2000 hrs. or 8 years whichever comes first
Miscellaneous Items	Check the electronic control system operation	○	○ (1st time)				
	Adjust the propeller shaft alignment		● (1st time)		●		
	Check / replace flexible engine mounts			○		◇	

1 Required to conform to U.S. EPA regulations. See *EPA Requirements USA Only* on page 76.

Note: These procedures are considered normal maintenance and are performed at the owner's expense.

Inspection and Maintenance of EPA Emission-Related Parts

Parts	Interval
Clean fuel injection nozzle	1500 hours
Check fuel injection nozzle adjustment	3000 hours
Check fuel injection pump adjustment	
Check turbocharger adjustment	
Check electronic engine management system (EMS) and its associated sensors and actuators	

Note: The inspection and maintenance items shown above to be performed at your Yanmar dealer or distributor.

PERIODIC MAINTENANCE PROCEDURES

After Initial 50 Hours of Operation

Perform the following maintenance after the initial 50 hours of operation.

- Replace Engine Oil and Engine Oil Filter
- Clean Centrifugal Oil Cleaner
- Check and Adjust Alternator Belt
- Check Electronic Management System (EMS) Operation
- Adjust Propeller Shaft Alignment
- Replace Crankcase Ventilation Filter

Replace Engine Oil and Engine Oil Filter Element

The engine oil on a new engine becomes contaminated from the initial break-in of internal parts. It is very important that the initial oil replacement is performed as scheduled.

It is easiest and most effective to drain the engine oil after operation while the engine is still warm.

WARNING



BURN HAZARD!

- If you must drain the engine oil while it is still hot, stay clear of the hot engine oil to avoid being burned.
- **ALWAYS** wear eye protection.
- Failure to comply could result in death or serious injury.

0000011en

CAUTION

- Only use the engine oil specified. Other engine oils may affect warranty coverage, cause internal engine components to seize, or shorten engine life.
- Prevent dirt and debris from contaminating engine oil. Carefully clean the oil cap / dipstick and the surrounding area before you remove the cap.
- **NEVER** mix different types of engine oil. This may adversely affect the lubricating properties of the engine oil.
- **NEVER** overfill. Overfilling may result in white exhaust smoke, engine overspeed or internal damage.

0000005en

CAUTION



- **ALWAYS** be environmentally responsible.
- Follow the guidelines of the EPA or other governmental agencies for the proper disposal of hazardous materials such as engine oil, diesel fuel and engine coolant. Consult the local authorities or reclamation facility.
- **NEVER** dispose of hazardous materials irresponsibly by dumping them into a sewer, on the ground or into ground water or waterways.
- Failure to follow these procedures may seriously harm the environment.

0000013en

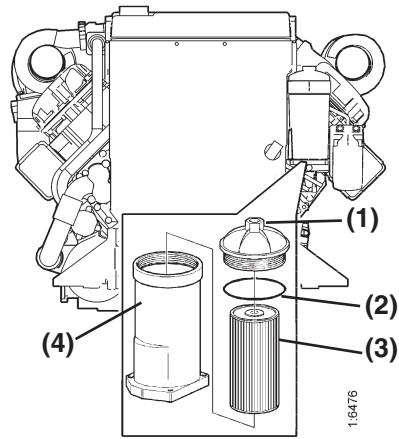

Figure 1

To replace the engine oil and engine oil filter element:

1. Remove the engine oil dipstick. Attach the oil drain pump (if equipped) and pump out the oil.
For easier draining, remove the engine oil fill cap.
2. Turn the engine oil filter lid (**Figure 1, (1)**) clockwise with a box wrench to remove.
3. Lift out the filter housing lid (**Figure 1, (1)**) with filter (**Figure 1, (3)**). The filter housing will drain automatically once the filter has been removed.

4. Remove the filter element (**Figure 1, (3)**) from the lid (**Figure 1, (1)**) by carefully bending the filter to one side.
5. Remove the O-ring (**Figure 1, (2)**) from the lid (**Figure 1, (1)**).
6. Lubricate a new O-ring with clean engine oil and install in the lid (**Figure 1, (1)**).
7. Press a new filter element (**Figure 1, (3)**) into the snap fastener in the lid.
8. Make sure that all oil is drained from the filter housing.
9. Replace the filter lid (**Figure 1, (1)**) and tighten to 25 N·m (18 ft·lb).

Note: If the deposits in the centrifugal cleaner are more than 20 mm (3/4 in.) thick, replace the oil filter more often. The same is true for cleaning the centrifugal oil cleaner and changing the oil. See *Clean the Centrifugal Engine Oil Cleaner* on page 83

10. Fill with new engine oil. See *Adding Engine Oil* on page 40.

CAUTION

- **NEVER** overfill the engine with engine oil.
- **ALWAYS** keep the oil level between upper and lower lines on the oil cap / dipstick.

0000015en

11. Perform a trial run and check for oil leaks.
12. Approximately 10 minutes after stopping the engine, remove the oil dipstick and check the oil level. Add oil if the level is too low.

Clean the Centrifugal Engine Oil Cleaner

WARNING



BURN HAZARD!

- If you must drain the engine oil while it is still hot, stay clear of the hot engine oil to avoid being burned.
- **ALWAYS** wear eye protection.
- Failure to comply could result in death or serious injury.

0000011en

Clean the centrifugal engine oil cleaner every time the oil is changed.

1. Clean the oil cleaner cover. Turn the nut counterclockwise to remove. Carefully remove the cover in case the oil is hot.

2. Lift out the rotor and turn the nut on the rotor bowl counterclockwise three turns (Figure 2).

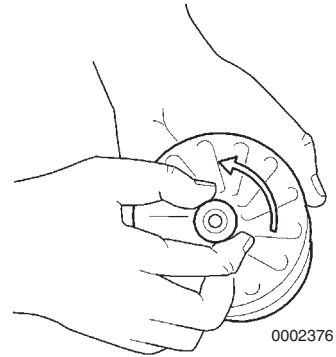

Figure 2

- If the nut is jammed, clamp the nut in a vise and turn the rotor three turns counterclockwise by hand or with a wrench (Figure 3).

IMPORTANT

NEVER clamp the rotor in a vise.
NEVER strike the rotor bowl.
 Doing so may cause damage resulting in imbalance.

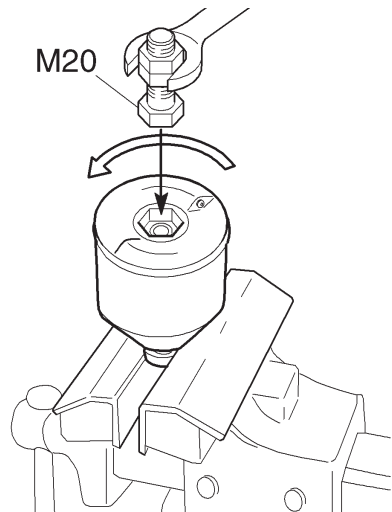

Figure 3

PERIODIC MAINTENANCE

3. Grasp the rotor bowl and tap on the rotor nut with your hand or a plastic hammer to loosen the rotor from the bowl.
4. Remove the strainer located on the rotor (Figure 4). If the strainer is stuck, use a screwdriver to carefully pry the bottom edge until it comes loose from the bottom plate.

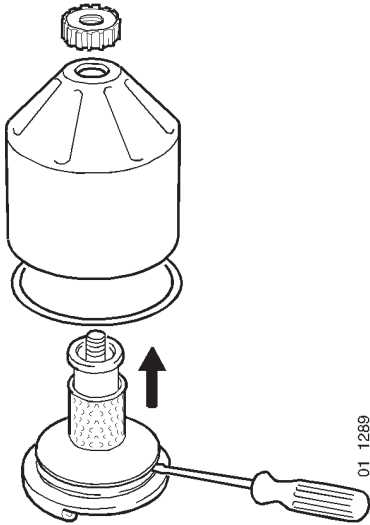

Figure 4

5. Scrape off the deposits from the inside of the rotor bowl (Figure 5).
 - If there are no deposits, the cleaner is not working properly.
 - If the deposits are thicker than 20 mm (3/4 in.), clean the oil cleaner more often.

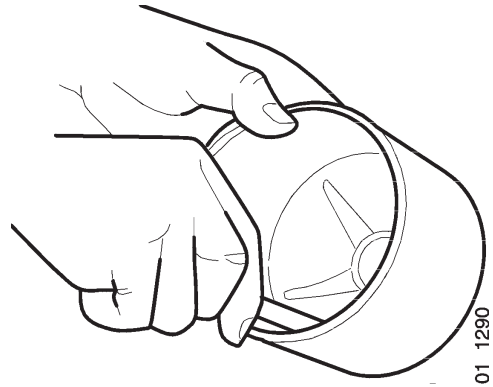

Figure 5

6. Wash all of the parts in suitable parts cleaning solvent.
7. Make sure the nozzles on the rotor are not blocked or damaged.
8. Make sure the bearings are not damaged.
9. Inspect the O-ring in the rotor bowl for damage and replace if necessary.
10. Install the O-ring in the rotor bowl (Figure 6).

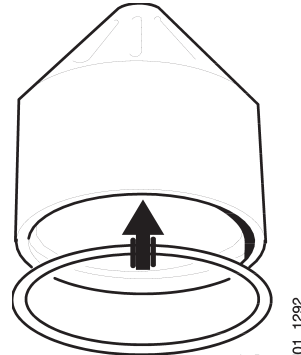

Figure 6

Reassemble the Rotor

1. Tighten the rotor nut firmly by hand (Figure 7).



Figure 7

01 1294

2. Make sure the shaft is not loose. If the shaft is loose, see your authorized Yanmar marine dealer or distributor.
3. Install the rotor. Turn the rotor by hand to make sure that it rotates easily (Figure 8).

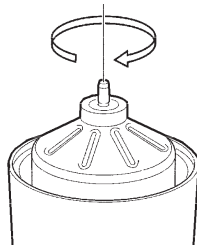

Figure 8

4. Install the bowl and tighten the lock nut to 15 N·m (133 in.-lb) (Figure 9, (1)). Be careful not to damage the rotor shaft, nut or bowl while tightening the lock nut.

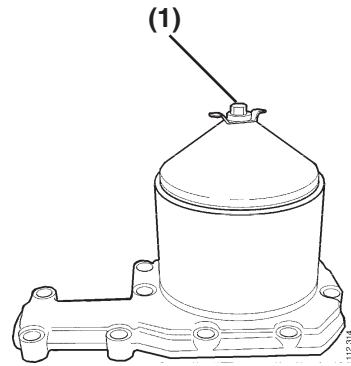

Figure 9

Functional Inspection

The rotor spins very fast and should continue to turn when the engine has stopped.

To check rotor rotation:

1. Stop the engine after it is warm.
2. Listen for a whirring sound from the rotor or check if the cleaner housing is vibrating.
 - The rotor normally continues spinning for 30 - 60 seconds after the engine has stopped.
 - If the rotor does not spin for 30 - 60 seconds after the engine has stopped, disassemble it and inspect the parts for damage.

Check and Adjust the Alternator Belt

WARNING



ENTANGLEMENT HAZARD!

- Stop the engine before you begin to service it.
- NEVER leave the key in the key switch when you are servicing the engine. Someone may accidentally start the engine and not realize you are servicing it. This could result in a serious injury.
- If you must service the engine while it is operating, remove all jewelry, tie back long hair, and keep your hands, other body parts and clothing away from moving / rotating parts.
- Failure to comply could result in death or serious injury.

0000010en

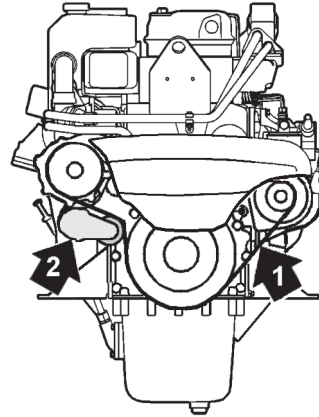

Figure 10

2. If the belt deflection is not to specification, see your authorized Yanmar dealer or distributor for belt replacement.

CAUTION

Be careful not to get any oil on the belt(s). Oil on the belt causes slipping and stretching. Replace the belt if it is damaged.

0000153enMarine

1. Check the belt by pushing on the middle of the belt (**Figure 10, (1)**) with your finger, exerting a force of approximately 98 N, 10 kgf (22 lbf). With proper tension, the belt should deflect 8 - 10 mm (0.315 - 0.393 in.).



Check Electronic Management System (EMS) Operation

Check for fault codes. Refer to separate manual provided by digital display manufacturer.

Adjust Propeller Shaft Alignment

Refer to reverse gear manufacturer literature for alignment procedure.

Replace the Closed Crankcase Ventilation Filter Element

 WARNING

<p>BURN HAZARD!</p> <ul style="list-style-type: none"> • If you must drain the engine oil while it is still hot, stay clear of the hot engine oil to avoid being burned. • ALWAYS wear eye protection. • Failure to comply could result in death or serious injury.
<small>0000011en</small>

CAUTION

<ul style="list-style-type: none"> • ALWAYS be environmentally responsible. • Follow the guidelines of the EPA or other governmental agencies for the proper disposal of hazardous materials such as engine oil, diesel fuel and engine coolant. Consult the local authorities or reclamation facility. • NEVER dispose of hazardous materials irresponsibly by dumping them into a sewer, on the ground or into ground water or waterways. • Failure to follow these procedures may seriously harm the environment.
<small>0000013en</small>

CAUTION

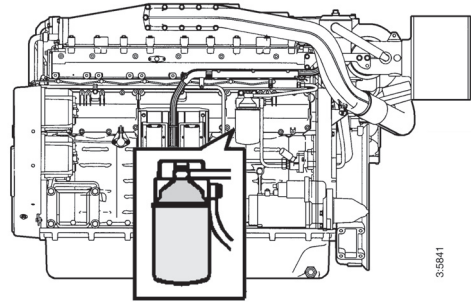
- Only use the engine oil specified. Other engine oils may affect warranty coverage, cause internal engine components to seize, or shorten engine life.
- Prevent dirt and debris from contaminating engine oil. Carefully clean the oil cap / dipstick and the surrounding area before you remove the cap.
- NEVER mix different types of engine oil. This may adversely affect the lubricating properties of the engine oil.
- NEVER overfill. Overfilling may result in white exhaust smoke, engine overspeed or internal damage.

000005en



33941

Figure 11

1. Remove the drain line at the filter base.
2. Release the clamps (**Figure 12, (2)**) holding the filter container (**Figure 12, (1)**) to the filter head.
3. Remove the filter container (**Figure 12, (1)**) carefully, there may be oil in the bottom of the container.
4. Remove the filter element.
5. Install a new O-ring at the base of the head and check that there is an O-ring on the top of the new filter.
6. Install the new filter into the center of the filter head and press firmly.

7. Replace the container and lock the clamps (**Figure 12, (2)**).
8. If the restriction indicator (**Figure 12, (3)**) on the top of the filter is red, remove the plastic cover and reset the restriction indicator button.
9. Reinstall the drainage line.

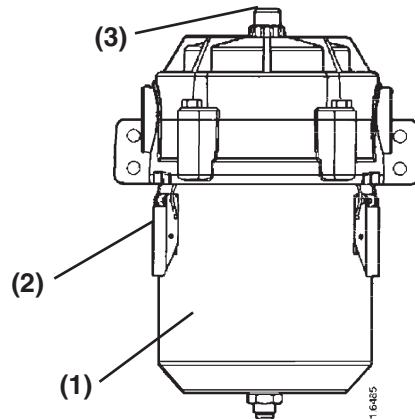

16485

Figure 12

Every 50 Hours of Operation

After you complete the initial 50 hour maintenance procedures, perform the following procedures every 50 hours thereafter.

- Drain Fuel Filter and Fuel Filter / Water Separator
- Check Battery Electrolyte Level

Drain or Replace the Fuel Filter Element and Fuel Filter / Water Separator

⚠ DANGER



FIRE AND EXPLOSION HAZARD!

- Diesel fuel is flammable and explosive under certain conditions.
- When you remove any fuel system component to perform maintenance (such as changing the fuel filter) place an approved container under the opening to catch the fuel.
- NEVER use a shop rag to catch the fuel. Vapors from the rag are flammable and explosive.
- Wipe up any spills immediately.
- Wear eye protection. The fuel system is under pressure and fuel could spray out when you remove any fuel system component.
- Failure to comply will result in death or serious injury.

000009en

CAUTION

If the fuel filter / water separator is positioned higher than the fuel level in the fuel tank, water may not drip out when the fuel filter / water separator drain cock is opened. If this happens, turn the air vent screw on the top of the fuel filter / water separator 2-3 turns counterclockwise.

Be sure to tighten the air vent screw after the water has drained out.

0000025en

CAUTION



- **ALWAYS** be environmentally responsible.
- Follow the guidelines of the EPA or other governmental agencies for the proper disposal of hazardous materials such as engine oil, diesel fuel and engine coolant. Consult the local authorities or reclamation facility.
- **NEVER** dispose of hazardous materials irresponsibly by dumping them into a sewer, on the ground or into ground water or waterways.
- Failure to follow these procedures may seriously harm the environment.

0000013en

Drain or Replace the Fuel Filter Element

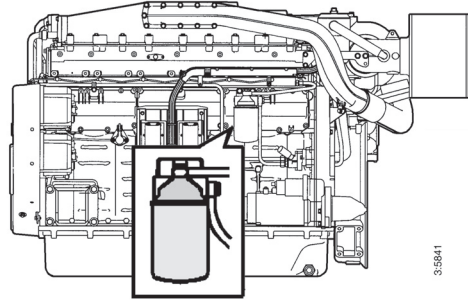

Figure 13

1. Close the fuel tank cock.
2. Loosen the drain plug. Drain off any water or dirt.
3. Clean the outside of the filter and remove it by turning it counterclockwise.
4. Install a new filter and hand-tighten.
5. Drain the fuel filter / water separator. *See Drain or Replace the Fuel Filter / Water Separator on page 91.*

Drain or Replace the Fuel Filter / Water Separator

1. Make sure the fuel tank cock (Figure 14, (1)) is closed.

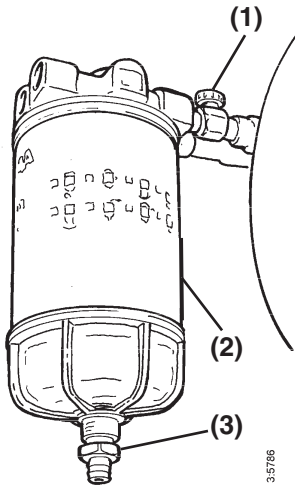

Figure 14

2. Loosen the drain plug (Figure 14, (3)) at the bottom of the fuel filter / water separator and drain off any water or dirt.
3. Turn the filter container (Figure 14, (2)) counterclockwise to remove.
4. Remove the filter element.
5. Lubricate the seal and install a new filter element into the container.
6. Install filter container and hand-tighten.
7. Open the fuel tank cock (Figure 14, (1)).
8. After reinstalling the fuel filter and the fuel filter / water separator, bleed air from the fuel system. See *Bleeding the Fuel System on page 36*.

Check the Battery Electrolyte Level (Servicable Batteries Only)

⚠ WARNING
<p style="text-align: center;">BURN HAZARD!</p> <ul style="list-style-type: none"> • Batteries contain sulfuric acid. NEVER allow battery fluid to come in contact with clothing, skin or eyes. Severe burns could result. ALWAYS wear safety goggles and protective clothing when servicing the battery. If battery fluid contacts the eyes and / or skin, immediately flush the affected area with a large amount of clean water and obtain prompt medical treatment. • Failure to comply could result in death or serious injury. <p style="text-align: right; font-size: small;">000007en</p>

CAUTION
<p>NEVER turn off the battery switch (if equipped) or short the battery cables during operation. Damage to the electric system will result.</p> <p style="text-align: right; font-size: small;">0000061en</p>

CAUTION



- **ALWAYS** be environmentally responsible.
- Follow the guidelines of the EPA or other governmental agencies for the proper disposal of hazardous materials such as engine oil, diesel fuel and engine coolant. Consult the local authorities or reclamation facility.
- **NEVER** dispose of hazardous materials irresponsibly by dumping them into a sewer, on the ground or into ground water or waterways.
- Failure to follow these procedures may seriously harm the environment.

0000013en

3. If the level is lower than the minimum fill level (**Figure 15, (1)**), fill with distilled water (**Figure 15, (2)**) (available in the grocery store) up to the upper limit (**Figure 15, (3)**) of the battery.

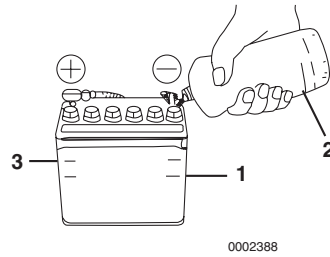

Figure 15

Note: The maximum fill level is approximately 10 - 15 mm (3/8-9/16 in.) above the plates.

Note: Battery fluid tends to evaporate in high temperatures, especially in summer. In such conditions, inspect the battery earlier than specified.

Check the Battery Electrolyte Level (Continued)

IMPORTANT

NEVER attempt to remove the covers or fill a maintenance-free battery.

1. Do not operate with insufficient battery electrolyte as the battery will be destroyed.
2. Remove the plugs and check the electrolyte level in all cells.

Every 250 Hours of Operation

Perform the following maintenance every 250 hours of operation.

- Check Unit Injector Spray Pattern
- Adjust Intake / Exhaust Valve Clearance (1st Time)
- Adjust Unit Injectors Rocker Arms (1st Time)
- Drain the Fuel Tank
- Replace the Fuel Filter Element
- Replace the Engine Oil (Crankcase)
- Replace the Engine Oil Filter Element
- Clean Centrifugal Engine Oil Cleaner
- Replace Crankcase Ventilation Filter
- Check the Seawater Pump Impeller
- Check and Replace the Anodes
- Clean the Air Intake Filter
- Clean the Turbocharger
- Flush the Charge Air Coolers
- Check the Wiring Connectors
- Tighten All Major Nuts and Bolts
- Check or Replace the Flexible Engine Mounts
- Drain, Flush and Refill Cooling System With New Coolant

Check Unit Injector Spray Pattern

See your authorized Yanmar marine dealer or distributor.

Adjust the Intake / Exhaust Valve Clearance

Proper adjustment is necessary to maintain the correct timing for opening and closing the valves. Improper adjustment will cause the engine to run noisily, resulting in poor engine performance and engine damage. See your authorized Yanmar marine dealer or distributor to adjust the intake / exhaust valve clearance.

Check and Adjust the Unit Injector Rocker Arms

Proper adjustment is necessary. See your authorized Yanmar marine dealer or distributor to adjust the unit injector rocker arms.

Drain the Fuel Tank

See the boat manufacturer's literature for procedure.

Replace the Fuel Filter Element

See *Drain or Replace the Fuel Filter Element* on page 90.

Replace the Engine Oil and Engine Oil Filter Element

See *Replace Engine Oil and Engine Oil Filter Element* on page 81.

Replace the Engine Oil and Engine Oil Filter Element

See *Replace Engine Oil and Engine Oil Filter Element* on page 81.

Clean Centrifugal Engine Oil Cleaner

See *Clean the Centrifugal Engine Oil Cleaner* on page 83.

Replace Crankcase Ventilation Filter

See *Replace the Closed Crankcase Ventilation Filter Element* on page 87.

Check or Replace the Anodes (Engines with Heat Exchangers)

Drain the seawater cooling circuit and check the anodes (**Figure 16**).

Note: Only two anodes are shown.

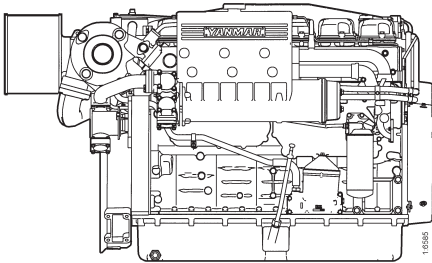

Figure 16

- Scrape off all loose material on the anodes.
- A new anode is 63 mm (2.50 in.) long with a diameter of 17 mm (11/16 in.). Replace an anode if less than half of the anode remains.

IMPORTANT

If operation is continued with an anode less than half of the new anode length, corrosion of the seawater coolant system will occur and water leakage or parts breakage will result.

Note: If the anodes are extremely corroded, check them more frequently.

Replace the Air Intake Filter

Note: Replace the air cleaner filter sooner than every 500 hours if the restriction indicator is red.

DANGER

NEVER start the engine unless the air filter is installed.

Failure to comply will result in death or serious injury.

0000025en

CAUTION

ALWAYS use genuine Yanmar replacement parts (super-fine mesh filter). Using anything except genuine Yanmar parts can cause engine damage, uneven engine performance and shorten engine life.

0000027en

1. Loosen clamps.
2. Remove the filter element.
3. Carefully blow the filter element clean from the inside with dry compressed air or install new filter element in housing.

Note: There is a risk of damaging the filter when it is cleaned. The filter can only be cleaned a maximum of four times. A cleaned filter does not filter as well as a new filter.

4. Insert a flashlight into the filter and check from the outside that there are no holes or cracks in the filter paper. Replace the filter if it has the slightest damage.
5. Mark the date the filter has been cleaned.
6. Reassemble the air cleaner in reverse order.
7. Tighten clamps securely.

8. Press the button to reset the red plunger (Figure 17) in the restriction indicator.

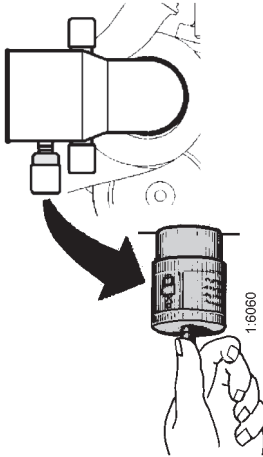

Figure 17

Clean the Turbocharger

Contamination of the turbocharger causes revolutions to drop and engine output to fall.

If a significant drop in engine output is noted (10% or more), clean the turbocharger.

This should be done only by a trained and qualified technician. See your authorized Yanmar marine dealer or distributor.

Clean the Charge Air Cooler

CAUTION

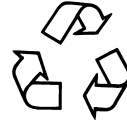

- **ALWAYS** be environmentally responsible.
- Follow the guidelines of the EPA or other governmental agencies for the proper disposal of hazardous materials such as engine oil, diesel fuel and engine coolant. Consult the local authorities or reclamation facility.
- **NEVER** dispose of hazardous materials irresponsibly by dumping them into a sewer, on the ground or into ground water or waterways.
- **Failure to follow these procedures may seriously harm the environment.**

0000013en

CAUTION

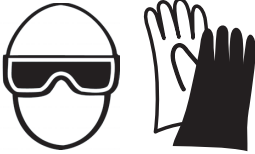

COOLANT HAZARD!

- Wear eye protection and rubber gloves when you handle Long Life engine coolant. If contact with the eyes or skin should occur, flush eyes and wash immediately with clean water.
- Failure to comply may result in minor or moderate injury.

000005enMarine

CAUTION

NEVER clean the coolant system with caustic soda. The aluminum parts may be damaged.

0000175en

1. Drain the coolant from the engine. See *Drain, Flush, and Refill the Engine Coolant* on page 97.
2. Remove the connection pipe between upper intake manifold housings.
3. Disconnect the pipe between intake manifold and turbocharger.
4. Disconnect inlet and outlet water lines from charge air cooler fittings. Cap the fittings to prevent coolant spillage.
5. Remove the upper intake manifold housing.

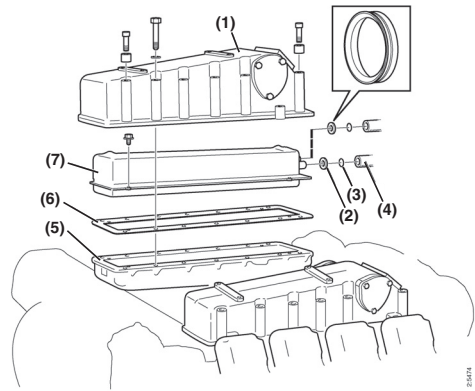

Figure 18

1. Upper Intake Housing
2. Seal
3. O-Ring
4. Coolant Pipe
5. Lower Intake Manifold
6. Gasket
7. Intake Air Cooler

IMPORTANT

Take care to ensure that no coolant spills from the element into the intake manifold.

6. Remove the charge air cooler assembly from the intake manifold.

IMPORTANT

Under no circumstances should caustic soda be used to clean the components.

7. Clean the element using paraffin-based engine detergent only.
8. Clean and degrease the sealing surfaces on the upper and lower intake manifold housing.
9. Install charge air cooler(s) using a new gasket. Tighten bolts to 20 N·m (177 in.-lb).
10. Install upper intake manifold(s). Tighten bolts to 50 N·m (37 ft-lb).

11. Install connection pipe between intake manifolds.
12. Connect coolant hoses to charge air coolers.
13. Install and secure all remaining air inlet pipes and hoses. Tighten 'V'-clamps to:
 - M6 Screw - 8 N·m (71 in.-lb)
 - M8 Screw - 20 N·m (177 in.-lb)
14. Fill the system with coolant. *See Drain, Flush, and Refill the Engine Coolant on page 97.*
15. Start the engine and check for coolant leaks. Check the level of the coolant and fill as necessary.

Check the Wiring Connectors

See your authorized Yanmar marine dealer or distributor.

Tighten All Major Nuts and Bolts

See your authorized Yanmar marine dealer or distributor.

Check or Replace Flexible Engine Mounts

See your authorized Yanmar marine dealer or distributor.

Drain, Flush, and Refill the Engine Coolant

Cooling performance drops when coolant is contaminated with rust and scale. The coolant must be replaced periodically because its properties deteriorate over time.

! DANGER



SCALD HAZARD!

- **NEVER** remove the coolant filler cap if the engine is hot. Steam and hot engine coolant will escape and seriously burn you. Allow the engine to cool sufficiently before attempting to remove the filler cap.
- **Securely** tighten the filler cap after checking the coolant level. Steam can escape during engine operation if the cap is loose.
- **Failure to comply will result in death or serious injury.**

000002enMarine

! WARNING



BURN HAZARD!

- **Wait** until the engine cools before draining seawater from the cooling system. Hot seawater may splash and burn you.
- **Failure to comply could result in death or serious injury.**

000016enMarine

CAUTION



- **ALWAYS** be environmentally responsible.
- Follow the guidelines of the EPA or other governmental agencies for the proper disposal of hazardous materials such as engine oil, diesel fuel and engine coolant. Consult the local authorities or reclamation facility.
- **NEVER** dispose of hazardous materials irresponsibly by dumping them into a sewer, on the ground or into ground water or waterways.
- Failure to follow these procedures may seriously harm the environment.

0000013en

CAUTION

- Only use the engine coolant specified. Other engine coolants may affect warranty coverage, cause an internal buildup of rust and scale and / or shorten engine life.
- Prevent dirt and debris from contaminating engine coolant. Carefully clean the heat exchanger cap and the surrounding area before you remove the cap.
- **NEVER** mix different types of engine coolants. This may adversely affect the properties of the engine coolant.

0000006enTrans

1. Remove the fill cap from the coolant recovery tank.
2. Drain the coolant:
 - from the two drain taps on the lower right side of the block (**Figure 19, (2)**)
 - from the drain tap (**Figure 19, (1)**) located on the lower left side of the block
 - from the two holes (remove the plugs) below the heat exchanger (if equipped)

Clean the Coolant System

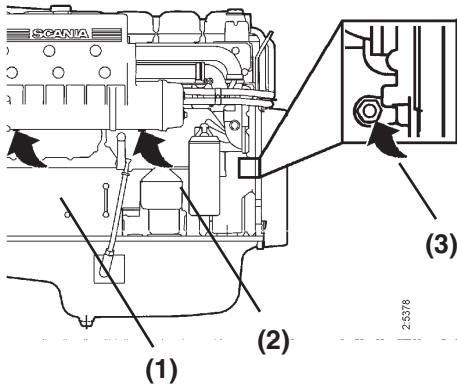

Figure 19

3. Close the drain taps (Figure 19, (1), (2)) and replace the heat exchanger plugs (if equipped).
4. Fill the coolant recovery tank with coolant through the expansion tank fill hole (Figure 19, (3)). See *Engine Coolant* on page 40 for refilling coolant.

! DANGER



SCALD HAZARD!

- NEVER remove the coolant filler cap if the engine is hot. Steam and hot engine coolant will escape and seriously burn you. Allow the engine to cool sufficiently before attempting to remove the filler cap.
- Securely tighten the filler cap after checking the coolant level. Steam can escape during engine operation if the cap is loose.
- Failure to comply will result in death or serious injury.

000002enMarine

! WARNING



BURN HAZARD!

- Wait until the engine cools before draining seawater from the cooling system. Hot seawater may splash and burn you.
- Failure to comply could result in death or serious injury.

0000016enMarine

CAUTION



- **ALWAYS** be environmentally responsible.
- Follow the guidelines of the EPA or other governmental agencies for the proper disposal of hazardous materials such as engine oil, diesel fuel and engine coolant. Consult the local authorities or reclamation facility.
- **NEVER** dispose of hazardous materials irresponsibly by dumping them into a sewer, on the ground or into ground water or waterways.
- Failure to follow these procedures may seriously harm the environment.

0000013en

⚠ CAUTION



COOLANT HAZARD!

- Wear eye protection and rubber gloves when you handle Long Life engine coolant. If contact with the eyes or skin should occur, flush eyes and wash immediately with clean water.
- Failure to comply may result in minor or moderate injury.

0000005enMarine

CAUTION

- Only use the engine coolant specified. Other engine coolants may affect warranty coverage, cause an internal buildup of rust and scale and / or shorten engine life.
- Prevent dirt and debris from contaminating engine coolant. Carefully clean the heat exchanger cap and the surrounding area before you remove the cap.
- **NEVER** mix different types of engine coolants. This may adversely affect the properties of the engine coolant.

0000006enTrans

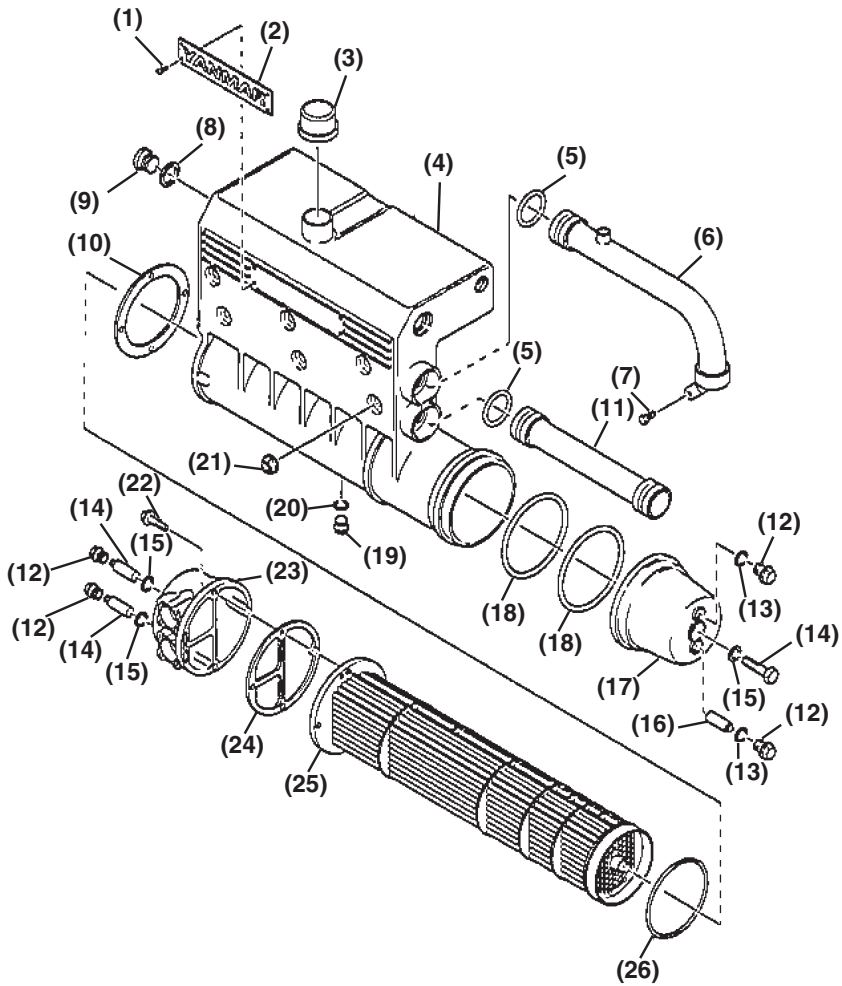

132246

Figure 20

- | | | |
|--------------------------------|------------------------|-----------------|
| 1. Screw | 10. Gasket | 20. Gasket |
| 2. Nameplate | 11. Outlet from Engine | 21. Flange Nut |
| 3. Filler Cap | 12. Bolt | 22. Bolt |
| 4. Heat Exchanger Housing | 13. Seal | 23. Rear Cover |
| 5. O-Ring | 14. Bolt | 24. Gasket |
| 6. Return Pipe to Coolant Pump | 15. Seal | 25. Cooler Core |
| 7. Bolt | 16. Anode (3 used) | 26. O-Ring |
| 8. Gasket | 17. Front Cover | |
| 9. Plug | 18. O-Ring | |
| | 19. Drain Plug | |

PERIODIC MAINTENANCE

Internal Cleaning - Heat Exchanger

1. Drain the coolant from the engine and from the heat exchanger. *See Drain, Flush, and Refill the Engine Coolant on page 97.*
 2. Drain the seawater circuit by removing the cover from the seawater pump and the connections from the heat exchanger outlet.
 3. Disconnect the coolant pipes from the charge air cooler. Disconnect the pipe between the front cover and the heat exchanger.
 4. Remove the connection housing at the coolant pump inlet together with the return pipe from the heat exchanger.
 5. Remove the thermostat housing cover and the outlet pipe to the heat exchanger.
 6. Remove the seawater inlet flange from the heat exchanger.
 7. Remove the vent pipe from the coolant recovery tank.
 8. Remove the flange nuts and lift off the complete heat exchanger assembly.
 9. Remove the rear cover and pull out the cooler element.
- IMPORTANT**
Under no circumstances should caustic soda be used to clean the components.
10. Use paraffin-based engine detergent to clean the element.
 11. Any internal deposits in the pipes can be removed mechanically using a round rod.
 12. Lubricate and install new a O-ring (**Figure 20, (26)**) inside the housing and install the cooler core.
 13. Install the front and rear covers using new O-rings and gaskets.

14. Install the heat exchanger assembly on the engine. Tighten the flange nuts to 50 N·m (37 ft-lb).
15. Install the coolant inlet and outlet pipes, thermostat housing cover, connection housing, charge air cooler coolant pipes and thermostat housing.
16. Fill the system with coolant. *See Drain, Flush, and Refill the Engine Coolant on page 97.*
17. Start the engine and check for coolant leaks. Check the level of the coolant and fill as necessary.

Flushing Closed Cooling System

CAUTION

<p style="text-align: center;">COOLANT HAZARD!</p> <ul style="list-style-type: none">• Wear eye protection and rubber gloves when you handle Long Life engine coolant. If contact with the eyes or skin should occur, flush eyes and wash immediately with clean water.• Failure to comply may result in minor or moderate injury. <p style="text-align: right; font-size: small;">000005enMarine</p>

CAUTION
<p style="text-align: center;">NEVER clean the coolant system with caustic soda. The aluminum parts may be damaged.</p> <p style="text-align: right; font-size: small;">0000175en</p>

CAUTION

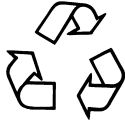

- **ALWAYS** be environmentally responsible.
- **Follow the guidelines of the EPA or other governmental agencies for the proper disposal of hazardous materials such as engine oil, diesel fuel and engine coolant. Consult the local authorities or reclamation facility.**
- **NEVER** dispose of hazardous materials irresponsibly by dumping them into a sewer, on the ground or into ground water or waterways.
- **Failure to follow these procedures may seriously harm the environment.**

0000013en

1. If possible, run the engine until it has reached operating temperature and then drain the coolant system. *See Drain, Flush, and Refill the Engine Coolant on page 97.*
2. Remove the thermostats.
3. Fill the system (including the heat exchanger, if equipped) with clean, hot water mixed with liquid dishwasher detergent designed for household use or a product intended to clean automotive cooling systems, and approved for use with aluminum components.
Concentration: 1% (0.1 / 10 L)
(0.1 / 10 qt).
4. Run the engine until warm (about 20 - 30 minutes).
5. Drain the coolant system. *See Drain, Flush, and Refill the Engine Coolant on page 97.*
6. Fill the system again using clean, hot water and run the engine for about 20 - 30 minutes.
7. Drain the water from the system.
8. Reinstall the thermostats.
9. Fill the system with new coolant. *See Engine Coolant on page 40* for refilling coolant.
10. Refill the system with hot water and run the engine for about 20 - 30 minutes.
11. Drain the water from the system.
12. Reinstall the thermostats.
13. Fill the system with new coolant. *See Check Diesel Fuel, Engine Oil, and Engine Coolant Levels on page 45* for refilling coolant.

Every 500 Hours of Operation

Perform the following maintenance every 500 hours of operation.

- Replace Seawater Pump Impeller
- Adjust the Propeller Shaft Alignment
- Check Alternator Belt Tension

Check or Replace the Seawater Pump Impeller (Engines with Heat Exchanger)

⚠ WARNING



BURN HAZARD!

- Wait until the engine cools before draining seawater from the cooling system. Hot seawater may splash and burn you.
- Failure to comply could result in death or serious injury.

0000016enMarine

Depending on use, the inside parts of the seawater pump deteriorate and discharge performance drops.

At the specified interval or when the volume of seawater discharged is reduced, inspect the seawater pump:

1. Close the sea valve (seacock) if the marine water pump is under water.
2. Drain the seawater circuit.
3. Remove the marine water pump cap.
4. Check the impeller vanes for wear or damage.

IMPORTANT

If the impeller must be changed frequently, the seawater strainer must be replaced with a unit having better filtering capabilities.

Replace the Impeller

1. Remove the impeller using an impeller removal tool (**Figure 21, (1)**).
2. Install a new impeller and cap. If the cap seal is hard or damaged, replace it.

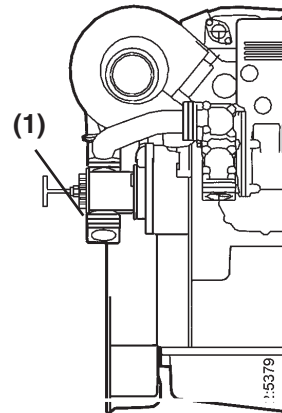

Figure 21

Note: A spare impeller should be kept on-board.

The impeller can become deformed during long periods of inactivity. Replace or remove the impeller before long periods of storage. See *Long-Term Storage* on page 113.

Adjust the Propeller Shaft Alignment

See *Adjust Propeller Shaft Alignment* on page 86.

Check the Alternator Belt Tension

See *Check and Adjust the Alternator Belt* on page 86.

Every 1000 Hours of Operation

Perform the following maintenance every 1000 hours of operation.

- Check the Unit Injector Spray Pattern
- Adjust Intake / Exhaust Valve Clearance
- Adjust Unit Injectors
- Clean and Check the Water Passages
- Replace Alternator Belt
- Replace Flexible Engine Mounts

Check the Unit Injector Spray Pattern

See your authorized Yanmar marine dealer or distributor.

Adjust Intake / Exhaust Valve Clearance

See *Adjust the Intake / Exhaust Valve Clearance* on page 93.

Adjust Unit Injectors

See your authorized Yanmar marine dealer or distributor.

Replace Flexible Engine Mounts

See your authorized Yanmar marine dealer or distributor.

Every 2000 Hours of Operation

Perform the following maintenance every 2000 hours of operation.

- Overhaul and Check Fuel Feed Pump
- Clean Engine Oil Cooler
- Clean Seawater and Engine Coolant System
- Replace Rubber Fuel Hoses

Overhaul and Check Fuel Feed Pump

See your authorized Yanmar marine dealer or distributor.

Clean Engine Oil Cooler

See your authorized Yanmar marine dealer or distributor.



Clean Seawater and Engine Coolant System

See *Clean the Coolant System* on page 99.



Replace Rubber Fuel Hoses



See your authorized Yanmar marine dealer or distributor.

Check the Battery Charge

 WARNING

<p>BURN HAZARD!</p> <ul style="list-style-type: none">• Batteries contain sulfuric acid. NEVER allow battery fluid to come in contact with clothing, skin or eyes. Severe burns could result. ALWAYS wear safety goggles and protective clothing when servicing the battery. If battery fluid contacts the eyes and / or skin, immediately flush the affected area with a large amount of clean water and obtain prompt medical treatment.• Failure to comply could result in death or serious injury.
000007en

CAUTION
<p>NEVER turn off the battery switch (if equipped) or short the battery cables during operation. Damage to the electric system will result.</p>
0000061en

 WARNING

<p>SHOCK HAZARD!</p> <ul style="list-style-type: none">• Turn off the battery switch (if equipped) or disconnect the negative battery cable before servicing the electrical system.• Check the electrical harnesses for cracks, abrasions, and damaged or corroded connectors. ALWAYS keep the connectors and terminals clean.• Failure to comply could result in death or serious injury.
000009en

 DANGER

<p>EXPLOSION HAZARD!</p> <ul style="list-style-type: none">• NEVER check the remaining battery charge by shorting out the terminals. This will result in a spark and may cause an explosion or fire. Use a hydrometer to check the remaining battery charge.• If the electrolyte is frozen, slowly warm the battery before you recharge it.• Failure to comply will result in death or serious injury.
000007en

Replace the Battery

Servicable Batteries Only

Measure the specific gravity of the battery with a hydrometer.

When the specific gravity of the fluid is 1.28 at 20°C (68°F), 1.294 at 0°C (32°F), 1.308 at -20°C (-4°F) the battery is fully charged. When the specific gravity is below 1.20, charge the battery.

A discharged battery will freeze at -5°C (23°F). If the specific gravity cannot be raised by charging, the battery must be replaced.

Do not rapid-charge the battery. Rapid-charging eventually results in damage to the battery.

Note: The capacities of the standard alternator and the recommended battery assume only the power necessary for regular operation. If the power is also used for lighting or other purposes, the generating and charging capacities may be insufficient. In such cases, see your authorized Yanmar marine dealer or distributor.

Maintenance-free batteries can be checked using a battery tester. See your authorized Yanmar marine dealer or distributor.

WARNING

- **Stop the engine and turn the starter switch key to the OFF position before checking or servicing the battery.**
- **Be sure to wear safety goggles when handling a battery.**
- **To disconnect the terminals, begin with the negative terminal (ground side); to connect the terminals, begin with the positive terminal. If a tool touches both the positive terminal and the machine, hazardous sparks may be generated.**
- **If a terminal is loose, hazardous sparks may be generated due to poor contact, which could cause ignition and explosion. Be sure to securely connect the terminals.**

0000118en

CAUTION



- **ALWAYS** be environmentally responsible.
- Follow the guidelines of the EPA or other governmental agencies for the proper disposal of hazardous materials such as engine oil, diesel fuel and engine coolant. Consult the local authorities or reclamation facility.
- **NEVER** dispose of hazardous materials irresponsibly by dumping them into a sewer, on the ground or into ground water or waterways.
- Failure to follow these procedures may seriously harm the environment.

0000013en

1. Disconnect the negative cable (-) first from the battery (ground cable).
2. Disconnect the positive cable (+) last from the battery (cable connected to starter motor).
3. Remove the battery and dispose of properly.

Install the Battery

1. Install the new battery.
2. Connect the positive cable (+) to the battery (cable connected to starter motor).
3. Connect the negative cable (-) last to the battery (ground cable).

Note: Be careful not to short circuit the battery.

Check for Leakage of Fuel, Engine Oil and Engine Coolant

Visually check the engine for fuel, engine oil or engine coolant leakage.

⚠ WARNING



ENTANGLEMENT HAZARD!

- Stop the engine before you begin to service it.
- **NEVER** leave the key in the key switch when you are servicing the engine. Someone may accidentally start the engine and not realize you are servicing it. This could result in a serious injury.
- If you must service the engine while it is operating, remove all jewelry, tie back long hair, and keep your hands, other body parts and clothing away from moving / rotating parts.
- Failure to comply could result in death or serious injury.

0000010en

CAUTION



- **ALWAYS** be environmentally responsible.
- Follow the guidelines of the EPA or other governmental agencies for the proper disposal of hazardous materials such as engine oil, diesel fuel and engine coolant. Consult the local authorities or reclamation facility.
- **NEVER** dispose of hazardous materials irresponsibly by dumping them into a sewer, on the ground or into ground water or waterways.
- Failure to follow these procedures may seriously harm the environment.

0000013en

5. Check that there are no leaks from the coolant pump. If a leak occurs, replace the pump seal or the coolant pump assembly.
6. A small amount of leakage from the overflow holes during the engine break-in period is normal. (Seals and O-rings are lubricated with soap or oil when installed). This leakage normally stops after time.

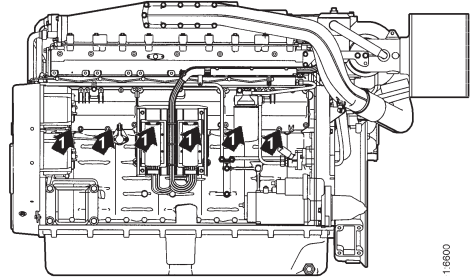





1-66900

Figure 22

1. Start the engine.
2. Check for oil, coolant, fuel, air and exhaust leaks.
3. Tighten or replace leaking connections.
4. Check the overflow holes (**Figure 22, (1)**) in the block. Leakage from these holes indicates that the O-rings between the cylinder liners and the crankcase are leaking.
 - If coolant is running out, the O-ring is leaking.
 - If oil is running out, the liner shelf is leaking.

Clean the Battery

 WARNING

<p>BURN HAZARD!</p> <ul style="list-style-type: none">• Batteries contain sulfuric acid. NEVER allow battery fluid to come in contact with clothing, skin or eyes. Severe burns could result. ALWAYS wear safety goggles and protective clothing when servicing the battery. If battery fluid contacts the eyes and / or skin, immediately flush the affected area with a large amount of clean water and obtain prompt medical treatment.• Failure to comply could result in death or serious injury. <p style="text-align: right;">000007en</p>

 WARNING

<p>SHOCK HAZARD!</p> <ul style="list-style-type: none">• Turn off the battery switch (if equipped) or disconnect the negative battery cable before servicing the electrical system.• Check the electrical harnesses for cracks, abrasions, and damaged or corroded connectors. ALWAYS keep the connectors and terminals clean.• Failure to comply could result in death or serious injury. <p style="text-align: right;">000009en</p>

1. Clean batteries, cables and cable terminals.
2. Check that all cable terminals are firmly tightened.
3. Apply petroleum jelly to battery terminal posts and cable terminals.

LONG-TERM STORAGE

If the engine is not to be used for an extended period of time, special measures should be taken to protect the coolant system, fuel system and combustion chamber from corrosion and the exterior from rusting.

The engine can normally stand idle for up to six months. If it remains unused for longer than this, please contact your authorized Yanmar marine dealer or distributor.

Winter Storage

Drain water from tank and fuel filters before and after extended storage.

To reduce the risk of condensation in the fuel tank during winter storage, fill the tank with fuel and treat with diesel fuel stabilizer.

This Page Intentionally Left Blank

SPECIFICATIONS

PRINCIPAL ENGINE SPECIFICATIONS

Engine Model	6SY-STP
Number of Cylinders	In-line 6
Type	Water-cooled, turbocharged
Combustion System	Direct injection
Aspiration	Turbocharged intercooler
Bore x Stroke	127 mm x 154 mm (5.0 in. x 6.063 in.)
Displacement	11.7 L (714 cu in.)
Firing Order	1-5-3-6-2-4
Compression Ratio	16:1
Maximum rated output at crankshaft (fuel 40°C [104°F]) +0% / -5%	
Output at rev speed	530 kW (720 hp) at 2300 rpm
Mean pressure	2.46 MPa (356.79 psi)
Idle Speed	
High idle	2400 rpm
Low idle	600 rpm
Rotation Direction	Counterclockwise (viewed from flywheel)
No. of Valves	
Inlet	2
Exhaust	2
Turbocharger	Single water-cooled
Electrical System	2-pole, 24 V*
Starter	6.7 kW (9.0 hp)
Charging System	65 A at 24V*
Battery Capacity - Recommended	160 Ah

SPECIFICATIONS

Engine Model		6SY-STP
Injection Timing		Variable (EMS controlled)
Maximum Allowable Exhaust Backpressure		1000 mmAq (39.37 in.Aq)
Cooling System		Closed cooling system with seawater heat exchanger
	Coolant capacity with expansion tank	40 L (10.5 gal)
Thermostats		
	Engine type and opening temperature	Dual - 75°C (167°F)
	Charge air cooler type and opening temperature	Single - 50°C (122°F)
Seawater Pump		Rubber impeller, gear driven
	Capacity	315 L/min at 2300 rpm (83 gpm at 2300 engine rpm)
Gear Oil Cooler Restriction		150 mbar (0.03495 psi)
Lubrication System		Totally enclosed, forced lube system
	Oil cooler	Closed coolant system
	Lube oil pressure - Rated speed	300 - 600 kPa (44 - 87 psi)
	Lube oil pressure - Idling speed	150 kPa (22 psi)
	Lube system capacity (with filters)	21-31 L (6 - 8.2 gal) approximate
Crankcase Ventilation		Closed, with filter
Engine Size		
	Height	1038 mm (40.9 in.)
	Length	Overall - 1559 mm (50.9 in.) Front Bell Housing - 1366 mm (53.8 in.)
	Width	867 mm (34.1 in.)
	Weight	1150 kg (2535 lb)

* *Optional dual 65A alternators available*

EPA WARRANTY USA ONLY

YANMAR CO., LTD. LIMITED EMISSION CONTROL SYSTEM WARRANTY - USA ONLY

The following EPA Warranty only applies to engines built on or after January 01, 2006 and labeled with the proper nameplate.

THIS EMISSION WARRANTY APPLIES TO THE ENGINES CERTIFIED TO UNITED STATES EPA 40 CFR 94 AND SOLD BY YANMAR THAT ARE INSTALLED IN VESSELS FLAGGED OR REGISTERED IN THE UNITED STATES.

Your Warranty Rights and Obligations:

Yanmar warrants to the first user and each subsequent purchaser the emission control system on your engine for periods of time listed below provided the engine has been installed according to Yanmar installation requirements and there has been no abuse, neglect, or improper maintenance of your Yanmar marine engine.

Yanmar warrants that the engine is designed, built and tested using genuine parts and equipped so as to conform to all applicable emission requirements of the U.S. Environmental Protection Agency and is free from defects in material and workmanship which would cause this engine to fail to conform to the applicable emission regulations over its limited emission control system warranty period.

Where a warrantable emissions condition exists, Yanmar will repair your engine at no charge to you for diagnosis, parts, and labor. Warranty service or repair will be provided at authorized Yanmar marine dealers or distributors.

It is recommended that any replacement parts used for maintenance, repair or replacement of emission control systems are Yanmar parts. The owner may elect to have maintenance, replacement or repair of the emission control components and systems performed by any repair establishment or individual and may elect to use parts other than Yanmar parts for such maintenance, replacement or repair. However, the cost of such service or parts and subsequent failures from such service or parts will not be covered under this emission control system warranty:

Warranty Period:

The warranty starts on either the date of delivery to the first end-user, or the date the unit is first leased, rented, or loaned.

1. For Pleasure Use: The warranty period is **five (5) years** or **2000 hours** of use, whichever occurs first. In the absence of a device to measure hours of use, the engine as a warranty period of **five (5) years**.
2. For Commercial Use: The warranty period is **five (5) years** or **5000 hours** of use, whichever occurs first. In the absence of a device to measure hours of use, the engine as a warranty period of **five (5) years**.

Warranty Coverage:

Repair or replacement of any warranted parts will be performed at an authorized Yanmar dealer or distributor. This limited emission control system warranty covers engine components that are a part of the emission control system of the engine as delivered by Yanmar to the original retail purchaser. Such components may include the following:

1. Fuel Injection System
2. Turbocharger System
3. Aftercooler
4. Electronic Engine Control Units and its associated Sensor and Actuators

Exclusions:

Failures other than those arising from defects in material and / or workmanship are not covered by this limited emissions warranty. This warranty does not extend to the following: malfunction caused by abuse, misuse, improper adjustment, modification, alteration, tampering, disconnection, improper or inadequate maintenance, improper storage or use of non-recommended fuels and lubricating oils, accident-caused damage, and replacement of expendable and / or consumable items made in connection with scheduled maintenance.

Owner's Responsibility:

As the Yanmar marine engine owner, you are responsible for the performance of the required maintenance listed in your *Operation Manual*. Yanmar recommends that you retain all documentation, including receipts, covering maintenance on your marine engine, but Yanmar cannot deny warranty solely for the lack of receipts or for your failure to ensure the performance of all scheduled maintenance.

Your engine is designed to operate on diesel fuel only. Use of any other fuel may result in your engine no longer operating in compliance with applicable emission requirements. You are responsible for initiating the warranty process. You must present your marine engine to an authorized Yanmar dealer or distributor as soon as a problem exists.

Customer Assistance:

If you have any questions regarding your warranty rights and responsibilities or would like information on the nearest authorized Yanmar dealer or distributor, you should contact Yanmar Marine USA Corporation for assistance.

Yanmar Marine USA Corporation

101 International Parkway
Adairsville, GA 30103
USA

Telephone: 770-877-9894

Fax: 770-877-7567

Declaration of Conformity for Recreational Craft Propulsion Engine with the Exhaust emission requirements of Directive 94/25/EC as amended by 2003/44/EC
(To be completed by manufacturer of inboard engines without integral exhaust)

Name of engine manufacturer: Yanmar Co., Ltd.

Street: 1-32 Town: Chayamachi, Kitaku, Osaka-City

Post Code: 530-8311 Country: Japan

Name of Authorised Representative: Yanmar Marine International B.V.

Street: Brugplein 11 Town: Almere-de Vaart

Post Code: 1332 BS Country: The Netherlands

Name of Notified Body for **exhaust emission assessment**: Société Nationale de Certification et d'Homologation

Street: 11, route de Luxembourg Town: Sandweiler

Post Code: L-5230 Country: Luxembourg ID Number: 0499

Module used for exhaust emission assessment: B+C B+D B+E B+F G H
 or engine type-approved according to: stage II of Directive 97/68/EC Directive 88/77/EC
 Other Community Directives applied: 89/336/EEC

DESCRIPTION OF ENGINE(S) AND ESSENTIAL REQUIERMENTS

Engine Type: z or stemdrive without integral exhaust Inboard engine
Fuel Type: Diesel Petrol
Combustion cycle: 2 stroke 4 stroke

Essential requirements	Standards Used	Other normative document used	See technical file
Annex I.B – Exhaust Emissions			
engine identification			
exhaust emission requirements	EN ISO 8178-1:1996		X
durability			
owner's manual			
Annex I.C – Noise Emissions	see craft manufacturer's Declaration of Conformity		

ENGINE(S) COVERED BY THIS DECLARATION

Engine model(s) or engine family name(s):	EC Type certificate number (exhaust)
	SNCH*94/25*2003/44*
RCD-1GM10X1	0009*00
RCD-2YM15X1	0004*00
RCD-3YM30X1	0005*00
RCD-4JH4X1	0014*00
RCD-4JH3TX1	0011*01
RCD-4LHAX1	0015*00
RCD-6LPADX1	0012*00
RCD-6LPASX1	0007*00
RCD-6CXMX1	0006*00
RCD-6LY2X1	0008*00
RCD-6LY3X1	0010*00
RCD-4JH3TX2	0016*00
RCD-4JH4TX2	0017*00

I declare on behalf of the engine manufacturer that the engine(s) will meet the exhaust emission requirements of Directive 94/25/EC as amended by Directive 2003/44/EC when installed in a recreational craft, in accordance with the engine manufacturer's supplied instructions and that this (these) engine(s) must not be put into service until the recreational craft into which it is (they are) to be installed has been declared in conformity with the relevant provisions of the above mentioned Directive.

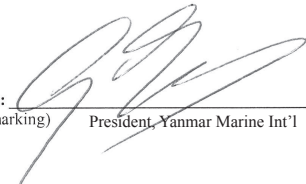
Name: G.J. Houtal Signature and title:  President, Yanmar Marine Int'l
 (identification of the person empowered to sign on behalf of the engine manufacturer or his authorised representative) (or an equivalent marking)

Date: (yr/month/day) 2005 / 10 / 21

Declaration of Conformity for Recreational Craft Propulsion Engine with the Exhaust and Noise emission requirements of Directive 94/25/EC as amended by 2003/44/EC
(To be completed by manufacturer of outboard or inboard engines with integral exhaust)

Name of engine manufacturer: Yanmar Co., Ltd.
 Street: 1-32 Town: Chayamati, Kitaku, Osaka-City
 Post Code: 530-8311 Country: Japan

Name of Authorised Representative (if applicable): Yanmar Marine International B.V.
 Street: Brugplein 11 Town: Almere-de Vaart
 Post Code: 1332 BS Country: The Netherlands

Name of Notified Body for **exhaust emission assessment**: Société National de Certification et d'Homologation
 Street: 11, route de Luxembourg Town: Sandweiler
 Post Code: L-5230 Country: Luxembourg ID Number: 0499

Name of Notified Body for **noise emission assessment**: Nederlands Keurings Instituut voor Pleziervaartuigen
 Street: Nipkowweg 9 Town: Joure
 Post Code: 8500 AB Country: The Netherlands ID Number: 0613

Module used for exhaust emission assessment: B+C B+D B+E B+F G H
 or engine type-approved according to: stage II of Directive 97/68/EC Directive 88/77/EC
 Module used for noise emission assessment: Aa G H
 Other Community Directives applied: 89/336/EEC

DESCRIPTION OF ENGINE(S) AND ESSENTIAL REQUIERMENTS

Engine Type: Outboard z or sterndrive with integral exhaust
 Fuel Type: Diesel Petrol
 Combustion cycle: 2 stroke 4 stroke

ENGINE(S) COVERED BY THIS DECLARATION

Engine model(s) or engine family name(s):	EC Type certificate number (exhaust)
RCD-4LHAX1	SNCH*94/25*2003/44*
4LHA-HTZP	0015*00
RCD-6LY2X1	0008*00
4LHA-DTZP	
4LHA-STZP	
RCD-6LPADX1	0012*00
6LPA-DTZP	
RCD-6LPASX1	0007*00
6LPA-STZP	

Essential requirements	Standards Used	Other normative document used	See technical file
Annex I.B – Exhaust Emissions			
engine identification (I.B.1)			<input type="checkbox"/>
exhaust emission requirements	EN ISO 8178-1:1996		<input checked="" type="checkbox"/>
durability			<input type="checkbox"/>
owner's manual			<input type="checkbox"/>
Annex I.C – Noise Emissions			
Noise emission levels (I.C.1)	EN ISO 14509		<input checked="" type="checkbox"/>
owner's manual (I.C.2)			<input type="checkbox"/>

I declare on behalf of the engine manufacturer that the engine(s) mentioned above complie(s) with all applicable essential requirements in the way specified and is in conformity with the type for which above mentioned EC type examination certificate(s) has been issued.

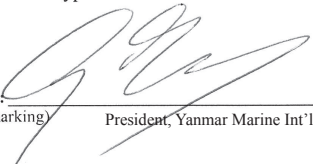
Name: G.J. Mantel Signature and title:  President, Yanmar Marine Int'l
 (identification of the person empowered to sign on behalf of the engine manufacturer or his authorised representative) (or an equivalent marking)

Date: (yr/month/day) 2005 / 10 / 20

This Page Intentionally Left Blank